

XD & XA SERIES

■ SPECIFICATION

■ GEAR HEAD



Model	Ratio		Number of stages	Continuous torque [Nm]	Permissible load [N]		Efficiency [%]	Weight [Kg]	
	(i : 1)	Coding			Axial	Radial			
XPG	42	4.5	A1	1	3.5(*0.9)	150	250	90	0.26
		6.25	B1						
		8	C1						
		16	A2	2	6	150	250	81	0.36
		25	B2						
		32	C2						
		50	D2						
		60	E2						
		100	A3	3	14	150	250	73	0.46
		128	B3						
		156	C3						
		200	D3						
		256	E3						
		312.5	F3						
		400	G3						
512	H3								

* : plastic planet gears

Model	Ratio		Number of stages	Continuous torque [Nm]	Permissible load [N]		Efficiency [%]	Weight [Kg]	
	(i : 1)	Coding			Axial	Radial			
XPG	52	4.5	A1	1	4.5(*1.2)	500	350	90	0.58
		6.25	B1						
		8	C1						
		15	A2	2	8	500	350	81	0.7
		20.25	B2						
		28.12	C2						
		36	D2						
		50	E2						
		64	F2	3	24	500	350	73	0.85
		91.12	A3						
		126.5	B3						
		162	C3						
		225	D3						
		288	E3						
		400	F3						
512	G3								

* : plastic planet gears

■ SPECIFICATION

■ GEAR HEAD

Model		Ratio				Number of stages	Continuous torque [Nm]	Permissible load [N]		Efficiency [%]	Weight [Kg]
		(i : 1)	Coding	(i : 1)	Coding			Axial	Radial		
XPG	63	3	A1	–	–	1	15(*5)	800	800	90	0.7
		4	B1	–	–						
		7	C1	–	–						
		10	D1	–	–						
		14,5	E1	–	–						
		16,8	A2	50	E2	2	70	800	800	81	1.2
		29,4	B2	60,9	F2						
		35	C2	70	G2						
		42	D2	101,5	H2						
		70,6	A3	250	G3	3	100	800	800	73	1.8
		84	B3	304,5	H3						
		100	C3	362,5	I3						
		147	D3	426,3	J3						
		175	E3	507,5	K3						
210	F3	710,5	L3								

* : plastic planet gears

Model		Ratio				Number of stages	Continuous torque [Nm]	Permissible load [N]		Efficiency [%]	Weight [Kg]
		(i : 1)	Coding	(i : 1)	Coding			Axial	Radial		
XPG	75	4	A1	–	–	1	25	1000	1000	90	1.5
		5,5	B1	–	–						
		7	C1	–	–						
		10	D1	–	–						
		14,5	E1	–	–						
		16,8	A2	42	F2	2	120	1000	1000	81	2.5
		23,1	B2	50	G2						
		27,5	C2	60,9	H2						
		29,4	D2	70	I2						
		35	E2	101,5	J2	3	160	1000	1000	73	3.6
		70,6	A3	250	H3						
		84	B3	304,5	I3						
		100	C3	362,5	J3						
		115,5	D3	426,3	K3						
147	E3	507,5	L3								
175	F3	710,5	M3								
210	G3	–	–								

XD & XA SERIES

XD6350 Series DC Motor Dimension

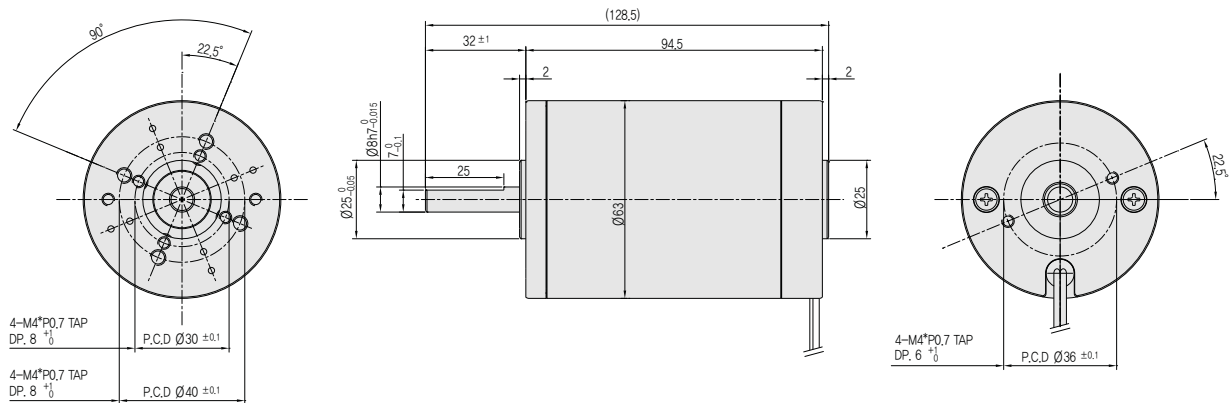

XD6350 Series DC Motor Data Sheet

Data	units	XD6350 Series			
Rated voltage	[Vd.c]	12	24	40	60
No load speed	[r/min]	3600	3600	3800	3600
No load current	[A]	1.2	0.6	0.4	0.25
Rated torque	[kgf.cm]	1.40	1.47	1.42	1.46
	[Ncm]	13.7	14.4	13.9	14.3
Rated speed	[r/min]	3150	3300	3450	3350
Rated current	[A]	4.9	2.6	1.7	1.0
Rated Output power	[W]	45	50	50	50
Stall torque	[kgf.cm]	10.9	11.6	14.3	13.7
	[Ncm]	106.9	114.1	139.7	134.2
Stall current	[A]	39.6	22.5	17.5	10.8
Demagnetization current	[A]	50	24	16	9.5
Weight	[kg]	1.2	1.2	1.2	1.2

XD6345-12 Characteristic diagram, 12Vd.c

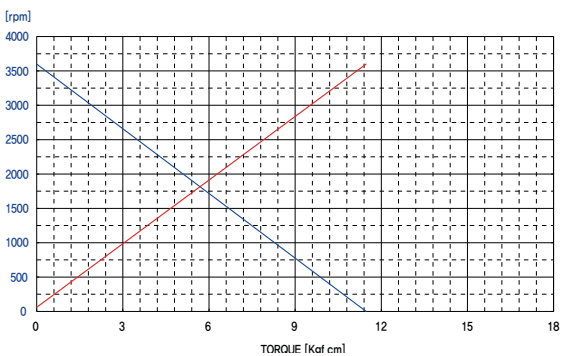

XD6350-24 Characteristic diagram, 24Vd.c

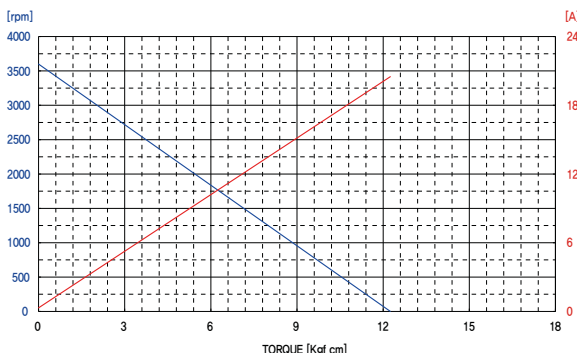

XD6350-40 Characteristic diagram, 40Vd.c

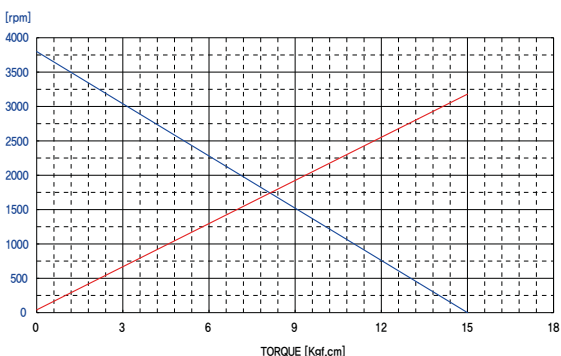

XD6350-60 Characteristic diagram, 60Vd.c

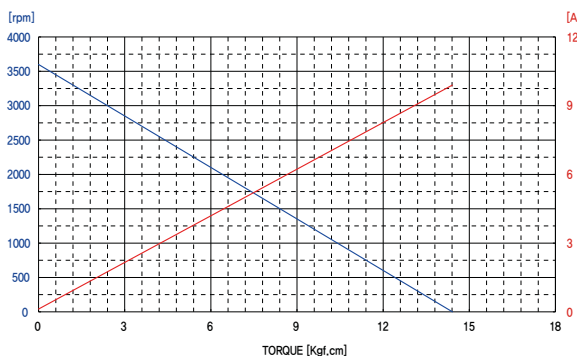

XD & XA SERIES

■ DIMENSIONS

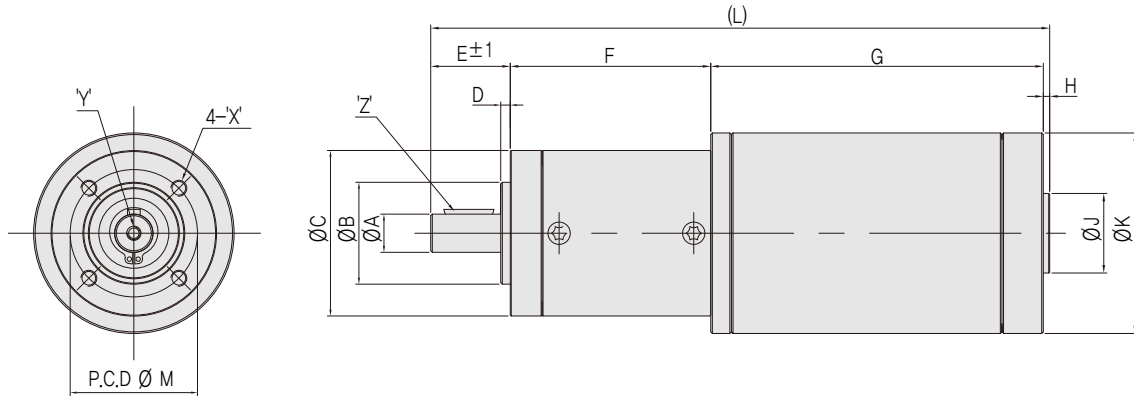

* Unit : [mm]

ITEM	XPG42+XD42		XPG52+XD52		XPG52+XD63		XPG63+XD63		XPG75+XD80	
A	Ø8	+0.007 +0.001	Ø12	+0.008 +0.003	Ø12	+0.008 +0.003	Ø15 h7		Ø19 h7	
B	Ø25	0 -0.052	Ø32	0 -0.039	Ø32	0 -0.039	Ø40	0 -0.011	Ø50	+0.011 -0.050
C	Ø42		Ø52		Ø52		Ø63		Ø75	
D	2		3		3		2.5		5	
E	25		25		25		32		49	
F	1stage	39.8	47.5	47.5	62.2	80.7				
	2stage	52.1	63	63	83.5	106.8				
	3stage	64.4	78	78	104.7	132.9				
M	Ø32 or 36		Ø40		Ø40		Ø52		Ø65	
X	M3 or M4, DP 8		M5, DP 7.5		M5, DP 7.5		M5, DP 10		M6, DP 16	
Y	-		-		-		-		M6, DP 18	
Z	Woodruff key		Woodruff key		Woodruff key		Parallel key		Parallel key	
G	15W	70	40W	95	45/50W	94.5	45/50W	94.5	120W	135
	20W	85	60W	125	75/100W	124.5	75/100W	124.5	220W	175
H	2		2		2		2		2	
J	Ø25		Ø25		Ø25		Ø25		Ø25	
K	Ø42		Ø52		Ø63		Ø63		Ø80	
L	1stage	137.8/152.8	169.5/199.5	169/199	190.7/220.7	266.7/306.7				
	2stage	149.6/164.6	185/215	184.5/214.5	212/242	292.8/332.8				
	3stage	161.4/176.4	200/230	199.5/229.5	233.2/263.2	318.9/358.9				

XD & XA SERIES

■ XD & XA SERIES



■ STANDARD FEATURE

- Planetary DC Geared motor
 - Compact & Robust design
 - High efficiency
 - Low noise
- All ball bearing
- Protection class : IP40(standard), IP 54(special)
- Insulation class : F Class (155°C)
- Special grease lubrication
- Ratio(i : 1) 3 to 710, other ratios on request
- Brake & Encoder can be added

■ CODING SYSTEM

■ DC MOTOR

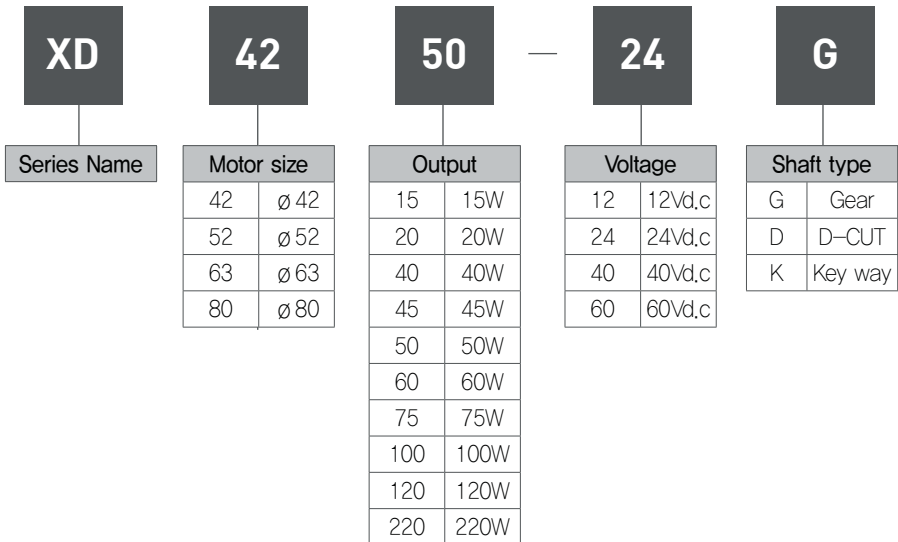

■ GEAR HEAD

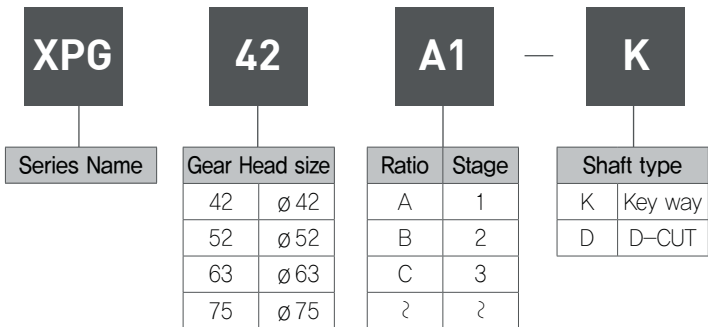

■ DC MOTOR AND GEAR HEAD COMBINATION

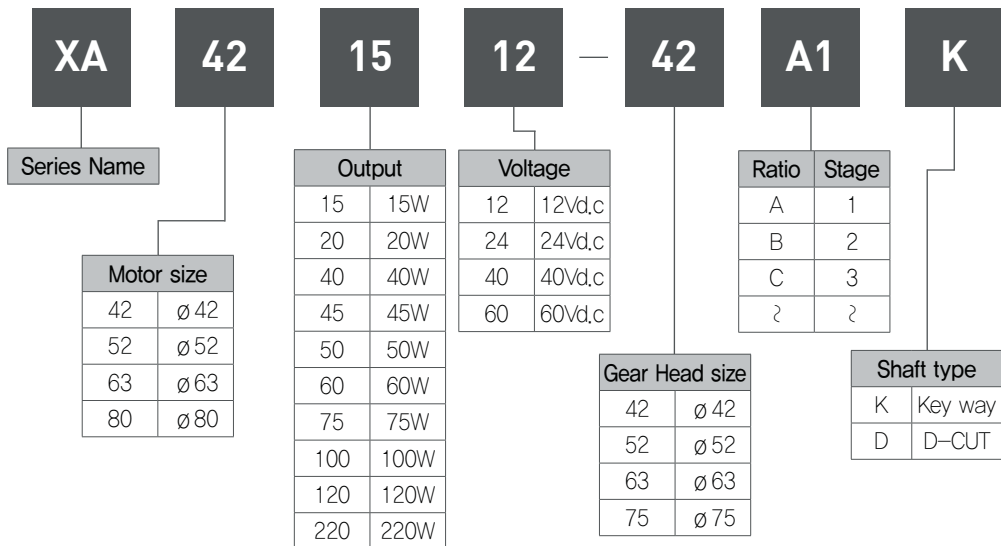

■ OPTIONS

■ Encoder

Magnet Encoder Modules

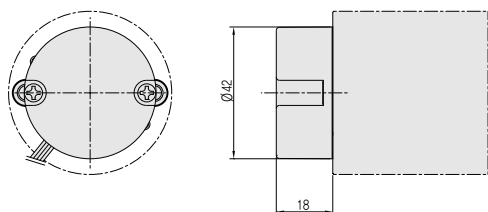

Optical Encoder Modules

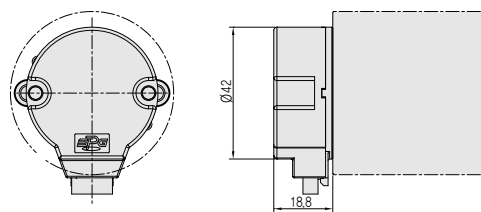
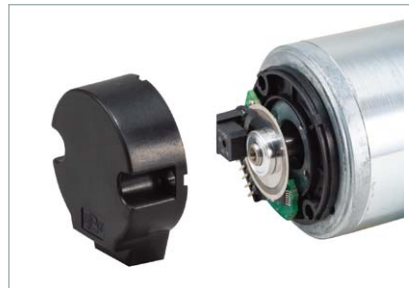

Model		Magnet Encoder Modules			Optical Encoder Modules		
		SEC 6-2	SEC 6-6	SEC 6-12	SEC 5-100	SEC 5-200	SEC 5-500
Resolution	[ppr]	2	6	12	100	200	500
Operating voltage	[Vdc]	12 (5 ~ 24)			5		
Pull-up resistor	-	Yes					
Output signal	-	2 square-wave signals of phase 90°					
Operating temperature	[°C]	-40 ~ 85					

※ This encoder is only available on request

■ OPTIONS

■ Electric brake(Power-off type)

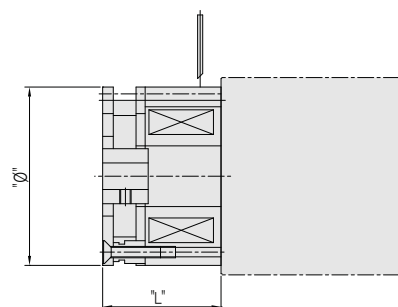
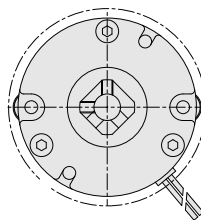

Model		#01	#02	#03	#04
Diameter "Ø"	[mm]	37	47	56	65
Length "L"	[mm]	32.1	30.2	31.8	31.7
Operating voltage	[Vdc]	24			
Braking torque	[Nm]	0.24	0.5	1	2
Turn on time	[s]	0.01	0.01	0.035	0.040
Turn off time	[s]	0.01	0.01	0.020	0.025

※ This power-on brake is only available on request