



# 6W

REVERSIBLE MOTOR □ 60mm LEAD WIRE TYPE

SIZE mm sq.	Type	Poles	Output (W)	Voltage (V)	Frequency (Hz)	Duty	Rated Load				Starting Torque		Capacitor (uF)
							Current (A)	Speed (rpm)	Torque (kg-cm) (N-m)		(kg-cm)	(N-m)	
60	S6R06GA S6R06GACE	4	6	1 ∅ 110	60	30min.	0.22	1550	0.40	0.040	0.60	0.060	3.0
	S6R06GB S6R06GBCE	4	6	1 ∅ 220	60	30min.	0.11	1550	0.40	0.040	0.60	0.060	0.8
	S6R06GC S6R06GCCE	4	6	1 ∅ 100	50	30min.	0.21	1200	0.50	0.050	0.45	0.045	3.0
	60				1500			0.42	0.042				
	S6R06GD S6R06GDCE	4	6	1 ∅ 200	50	30min.	0.10	1200	0.45	0.045	0.53	0.053	0.8
	60				1500			0.42	0.042				
	S6R06GE S6R06GECE	4	5.5	1 ∅ 100	50	30min.	0.19	1200	0.50	0.050	0.52	0.052	3.5
	60				1500			0.30	0.030				
	6				1 ∅ 115			60	0.18	1500			
	S6R06GX S6R06GXCE	4	5.8	1 ∅ 220	50	30min.	0.09	1200	0.47	0.047	0.50	0.050	0.7
6	1 ∅ 240								0.10	0.50			

- ❖ S6R06GE is UL approved (UL FILE No. E172722) impedance protected type.
- ❖ Appropriate capacitors shall be used according to the voltage for S6R06GE type since the size of the capacitor differs by different voltages. Malfunction may occur when not used properly. Capacitor for 115V will be delivered otherwise the required voltage is informed.
- ❖ CE marked at the end of model name indicates that it is impedance protected type which has received CE. S6R06GECE is available only for 115V specification.
- ❖ Data is measured with friction brake mounted.
- ❖ "L" or "H" type does not apply to motors under 40W.

## 50Hz

GEAR RATIO		3	3.6	5	6	7.5	9	10	12.5	15	18	20	25	30	36	40	50	60	75	90	100	120	150	180	200	250
MODEL	rpm	500	416	300	250	200	166	150	120	100	83	75	60	50	41	37	30	25	20	16	15	12	10	8	7.5	6
	kg-Cm	1.3	1.5	2.1	2.6	3.2	3.9	4.3	5.4	6.4	7.7	7.7	9.7	11.6	13.9	15.5	17.5	21.0	26.2	30.0	30.0	30.0	30.0	30.0	30.0	30.0
S6DA□B	N·m	0.127	0.147	0.206	0.255	0.314	0.382	0.421	0.529	0.627	0.755	0.755	0.951	1.137	1.362	1.519	1.715	2.058	2.568	2.942	2.942	2.942	2.942	2.942	2.942	2.942

## 60Hz

GEAR RATIO		3	3.6	5	6	7.5	9	10	12.5	15	18	20	25	30	36	40	50	60	75	90	100	120	150	180	200	250
MODEL	rpm	600	500	360	300	240	200	180	144	120	100	90	72	60	50	45	36	30	24	20	18	15	12	10	9	7.2
	kg-Cm	1.0	1.3	1.7	2.1	2.6	3.1	3.5	4.4	5.2	6.3	6.3	7.8	9.4	11.3	12.6	14.2	17.0	21.3	25.5	28.4	30.0	30.0	30.0	30.0	30.0
S6DA□B	N·m	0.098	0.127	0.167	0.206	0.255	0.304	0.343	0.431	0.510	0.617	0.617	0.764	0.921	1.107	1.235	1.392	1.666	2.087	2.499	2.783	2.942	2.942	2.942	2.942	2.942

- ❖ The code in □ of gearhead model is for gear ratio.
- ❖ It is the permissible torque of the assembled motor and gearhead.
- ❖ The permissible torque of the motor and inter-decimal gearhead is 30 kg-cm.
- ❖ ■ color indicates that the output shaft of the geared motor rotates in the same direction as the output shaft of the motor. Others indicate rotation in the opposite direction.
- ❖ Rpm is based on synchronous speed (50Hz: 1500rpm, 60Hz: 1800rpm) divided by gear ratio. The actual rotation speed can be 2~20% less than displayed value depending on the load.
- ❖ "L" or "H" type does not apply to motors under 40W.

# DIMENSIONS

## GEARED MOTOR

- ※ MOTOR MODEL : S6R06G□
- ※ HEAD MODEL : S6□A3□~S6□A250□

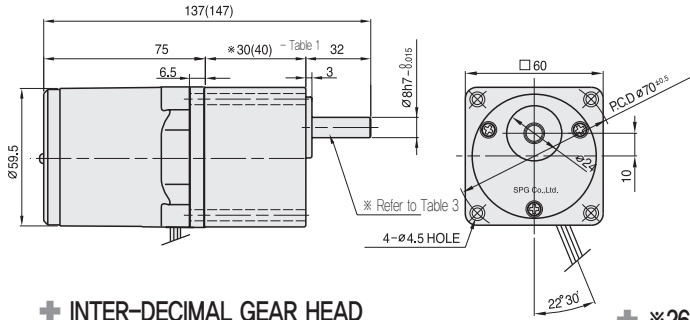

## INTER-DECIMAL GEAR HEAD

- ※ MODEL : S6GX10B

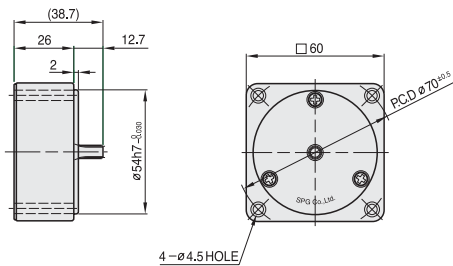

## ※26(35) - (Table1)

GEAR RATIO	SIZE(mm)
S6□A3□ ~ S6□A18□	30
S6□A20□ ~ S6□A250□	40

## WEIGHT - (Table2)

PART	WEIGHT(kg)	
MOTOR	0.70	
DECIMAL GEAR HEAD	0.18	
GEAR HEAD	S6□A3□ ~ S6□A18□	0.24
	S6□A20□ ~ S6□A40□	0.30
	S6□A50□ ~ S6□A250□	0.33

## KEY SPEC

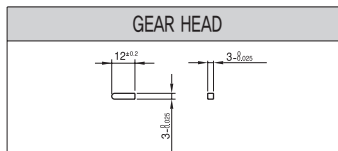

## MOTOR

- ※ MOTOR MODEL : S6R06□□

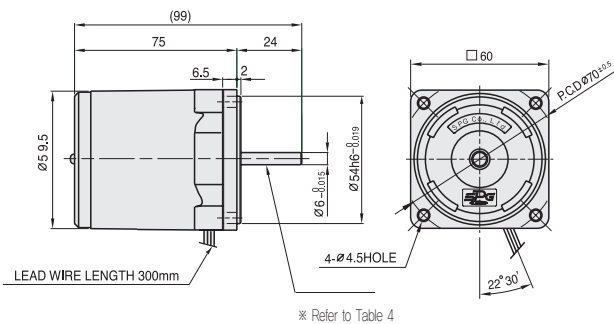

## SPEC for output shaft of gearhead - (Table3)

MODEL	TYPES OF OUTPUT SHAFT
STRAIGHT TYPE	
S6SA3□ ~ S6SA250□	
D-CUT TYPE	
S6DA3□ ~ S6DA250□	
KEY TYPE	
S6KA3□ ~ S6KA250□	

## SPEC for output shaft of motor - (Table4)

MODEL	TYPES OF OUTPUT SHAFT
GEAR TYPE	
S6R06G□	
STRAIGHT TYPE	
S6R06S□	
D-CUT TYPE	
S6R06D□	

# SCHEMATIC DIAGRAMS

The direction of motor rotation is as viewed from the front shaft end of the motor.

