

# Ezi-STEP<sup>®</sup>

## Micro Stepping System

- Intergrated Controller
- Position Table
- Micro Stepping
- Sensorless Stall Detection
- Software Damping
- Run / Stop Signal Output

**Plus-R  
MINI**



CE

**FASTECH**

Fast, Accurate, Smooth Motion

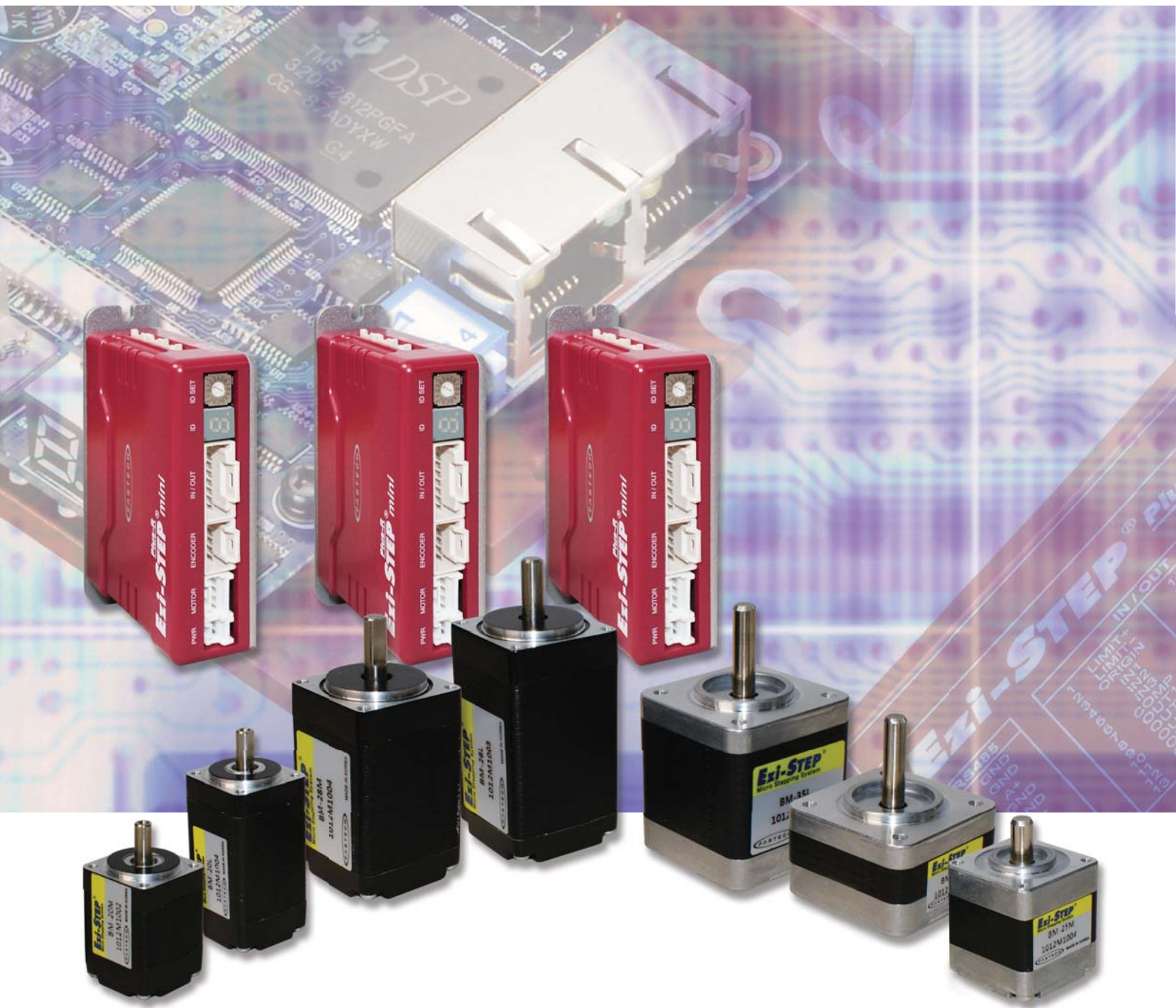

*Fast, Accurate, Smooth Motion*

# **Ezi-STEP** <sup>®</sup> **Plus-R** **MINI**

## **Micro Stepping System**

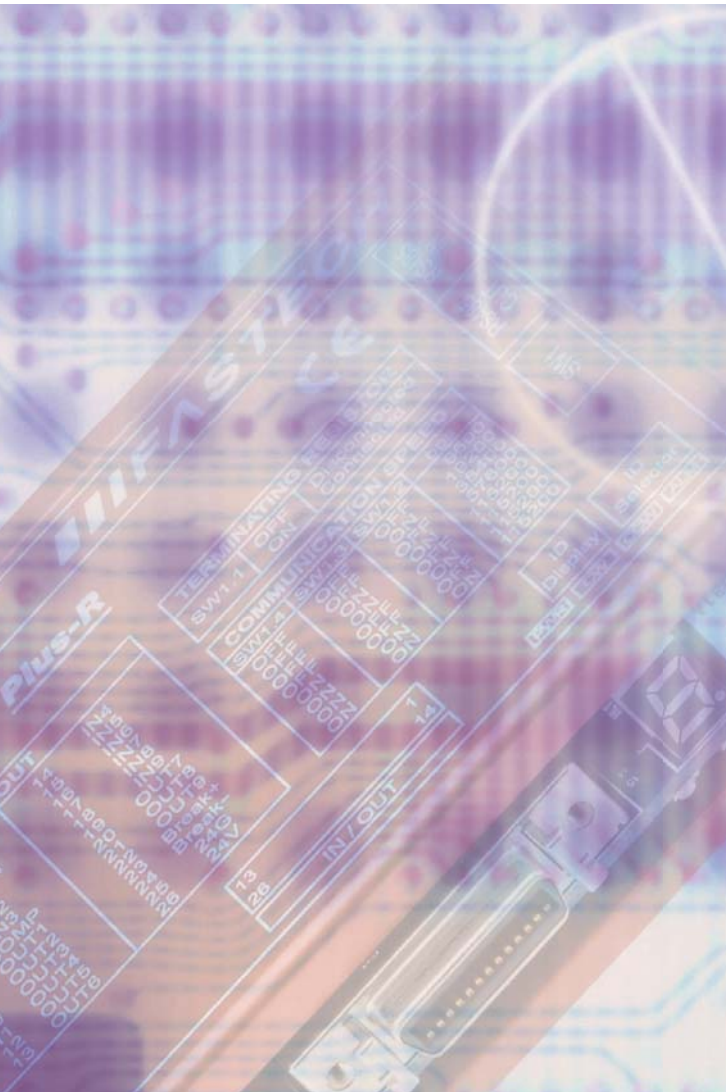

## 1 Network Based Motion Control

A maximum of 16 axis can be operated from a PC through RS-485 communications. All of the Motion conditions are set through the network and saved in Flash ROM as a parameter. Motion Library(DLL) is provided for programming under Windows 2000/XP.

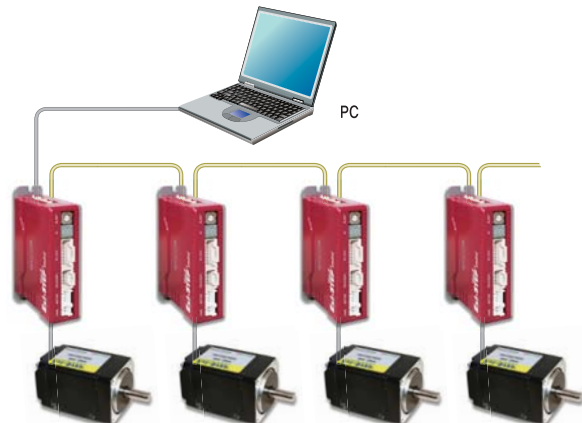

## 2 Position Table Function

Position Table can be used for motion control by digital input and output signals of host controller. You can operate the motor directly by sending the position table number, start/stop, origin search and other digital input values from a PLC.

The PLC can monitor the In-position, origin search, moving/stop, ready and other digital output signals from a drive. A maximum of 64 positioning points can be set from PLC.

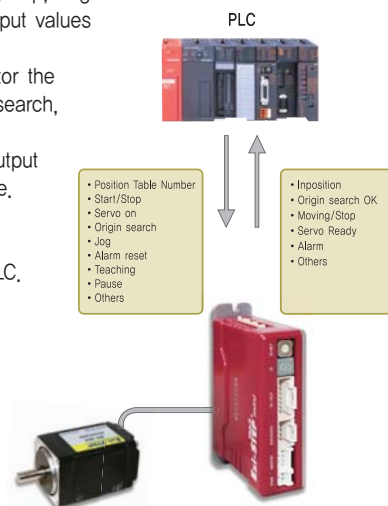

## 3 Microstep and Filtering

High precision Microstep function and Filtering (Patent pending)The high-performance DSP operates at step resolutions of  $1.8^\circ$  up to maximum  $0.0072^\circ$  (1/250 steps) and Ezi-STEP adjusts PWM control signal in every  $25\mu$  sec, which makes it possible for more precise current control, resulting in high-precision Microstep operation.

## 4 Sensorless Stall Detection

Detecting the loss-of-synchronization with on-board DSP (Patent pending)

Ezi-STEP can detect the loss-of-synchronization of a stepping motor without the addition of an external sensor. By monitoring the voltage, current, and back-emf signal, the on-board DSP estimates the current position of a rotor and enables it to detect the loss-of-synchronization (an impossible task for a conventional stepping motor drive), this allows for high-speed operation at 100% torque rating without loss-of-synchronization\*.  
\*Effective only over 300 [rpm]

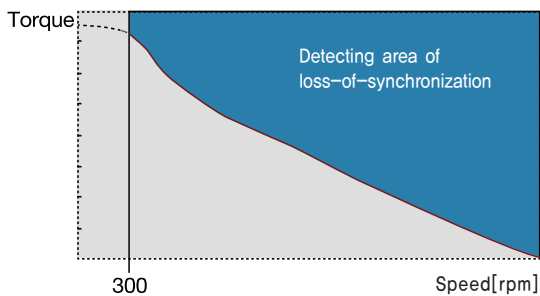

## 6 Software Damping

Vibration suppression and high-speed operation (Patent pending)

Motor vibration is created by magnetic flux variations of the motor, lower current from the drive due to back-emf from the motor at high speeds and lowering of phase voltages from the drive.

Ezi-STEP drive detects these problems and the DSP adjusts the phase of the current according to the pole position of the motor, drastically suppressing vibration. This allows the smooth operation of the motor at high speeds.

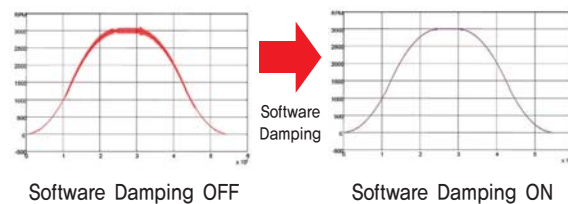

\*This is real measured speed that using 100000[pulse/rev] encoder.

## 5 Drive Output Signal Monitoring

Ezi-STEP provides loss of step, run/stop, over-current, over-heat, over-voltage, power, and motor connection alarms that can be monitored by the controller and visible by a motor-mounted flashing led indicator.

## 7 Improvement of High-Speed Driving

Depending on the speed of a stepping motor, Ezi-STEP automatically increases the supply voltage and prevents the torque lowering due to the low operating voltage to the motor caused by back-emf voltage, this enables high-speed operation. Additionally, the software damping algorithm minimizes the vibration and prevents the loss-of-synchronization at high-speed.

# ● Features of Motion Controller

## 1. Loop Count

This function allows positioning repeatedly according to the Loop Count Number.

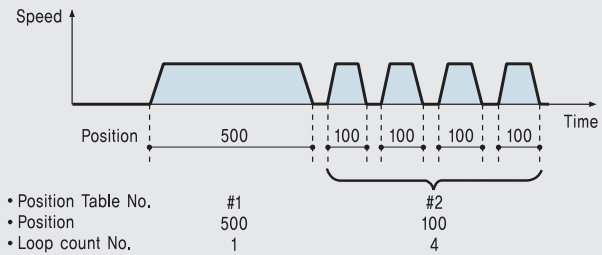

## 2. Acceleration/Deceleration

For quick acceleration and gradual deceleration, you can set each acceleration and deceleration time separately.

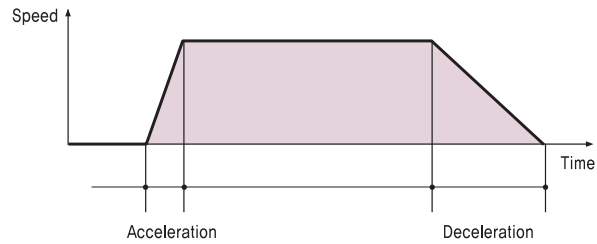

## 3. Pause

You can pause the motion upon the input of an external signal. When Pause signal change to OFF, the motor will restart to original target position.

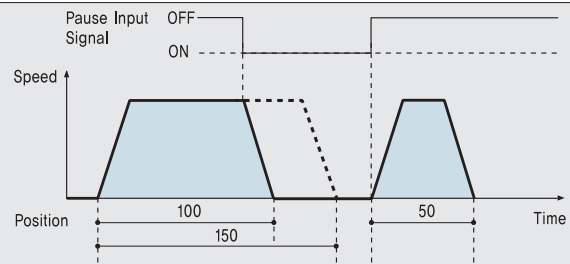

## 4. Alarm

The number of 7-Segment flashing time indicates which Alarm has occurred.

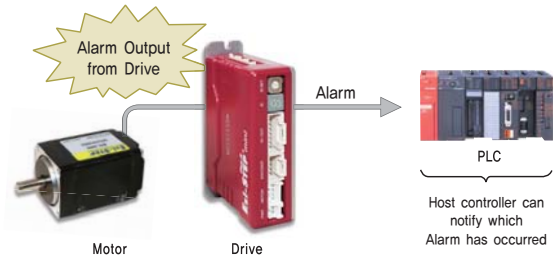

## 5. Teaching

Teaching signal is used to memorize current Position data into the selected Position Table item.

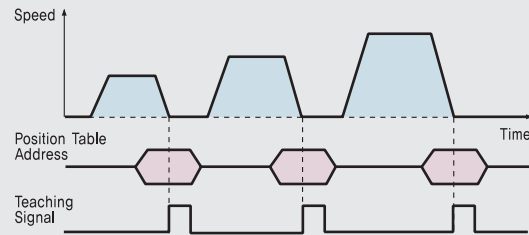

## 6. Jump

Within one Position Table, you can select various Position Table numbers that you want to jump. With three external input signal during movement, the next jump Position Table number can be select.

◆ Position Table #14

Position	---	Next	---	Input 1	Input 2	Input 3	---
10000		100		115	116	117	

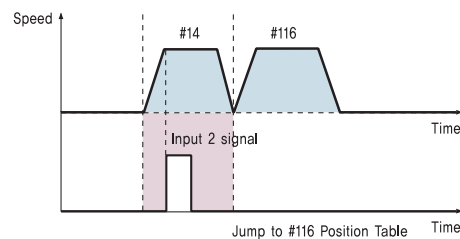
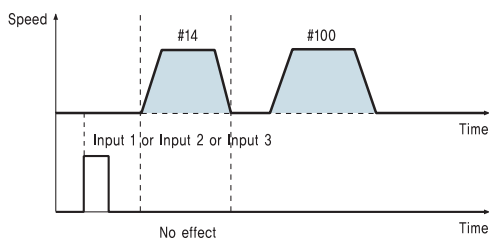

## ● Part Numbering

# Ezi-STEP-PR-MI-28S-□

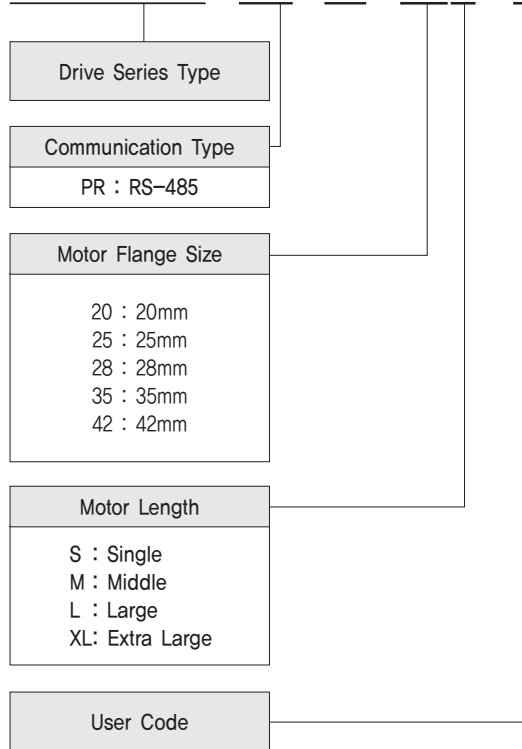

## ● Combination list of Ezi-STEP PR MINI

Unit Part Number	Motor Model Number	Drive Model Number
Ezi-STEP-PR-MI-20M	BM-20M	EzT-NDR-MI-20M
Ezi-STEP-PR-MI-20L	BM-20L	EzT-NDR-MI-20L
Ezi-STEP-PR-MI-25S	BM-25S	EzT-NDR-MI-25S
Ezi-STEP-PR-MI-25M	BM-25M	EzT-NDR-MI-25M
Ezi-STEP-PR-MI-25L	BM-25L	EzT-NDR-MI-25L
Ezi-STEP-PR-MI-28S	BM-28S	EzT-NDR-MI-28S
Ezi-STEP-PR-MI-28M	BM-28M	EzT-NDR-MI-28M
Ezi-STEP-PR-MI-28L	BM-28L	EzT-NDR-MI-28L
Ezi-STEP-PR-MI-35S	BM-35S	EzT-NDR-MI-35S
Ezi-STEP-PR-MI-35M	BM-35M	EzT-NDR-MI-35M
Ezi-STEP-PR-MI-35L	BM-35L	EzT-NDR-MI-35L
Ezi-STEP-PR-MI-35XL	BM-35XL	EzT-NDR-MI-35XL
Ezi-STEP-PR-MI-42S	BM-42S	EzT-NDR-MI-42S
Ezi-STEP-PR-MI-42M	BM-42M	EzT-NDR-MI-42M
Ezi-STEP-PR-MI-42L	BM-42L	EzT-NDR-MI-42L
Ezi-STEP-PR-MI-42XL	BM-42XL	EzT-NDR-MI-42XL

## ● Specifications

Motor Model	BM-20 series	BM-25 series	BM-28 series	BM-35 series	BM-42 series
Driver Model	EzT-NDR-MI-20 series	EzT-NDR-MI-25 series	EzT-NDR-MI-28 series	EzT-NDR-MI-35 series	EzT-NDR-MI-42 series
Input Voltage	24VDC $\pm$ 10%				
Control Method	PWM drive with 32bit DSP				
Multi Axes Drive	Maximum 16 axes through Daisy-Chain				
Position Table	64 motion command steps (Continuous, Wait, Loop, Jump and External start etc.)				
Current Consumption	Max 500mA (Except motor current)				
Operating Condition	Ambient Temperature	In Use : 0~50°C In Storage : -20~70°C			
	Humidity	In Use : 35~85% (Non-condensing) In Storage : 10~90% (Non-condensing)			
	Vib. Resist.	0.5G			
Function	Rotation Speed	0~3000rpm			
	Resolution(P/R)	500, 1000, 1600, 2000, 3200, 3600, 4000, 5000, 6400, 8000, 10000, 20000, 25000, 36000, 40000, 50000 (Selectable by parameter) <b>*Default : 10000</b>			
	Protection Functions	Over current, Over speed, Step out, Over temperature, Over regenerated voltage, Motor connect error, Motor voltage error, System error, ROM error, Input voltage error			
	LED Display	Power, Alarm, CW Rotation, CCW Rotation			
	STOP Current	10%~100% (Selectable by parameter) Current after 0.1 second after motor stop. <b>*Default : 50%</b>			
	Rotational Direction	CW / CCW (Selectable by parameter) Used when changing the direction of motor rotate. <b>*Default : CW</b>			
I/O Signal	Input Signal	3 dedicated input (LIMIT+, LIMIT-, ORIGIN), 9 programmable input (Photocoupler)			
	Output Signal	1 dedicated output (Compare Out), 9 programmable output (Photocoupler), Brake signal			
Communication Interface	The RS-485 serial communication with PC Transmission speed : 9,600~921,600[bps]				
Position Control	Incremental mode / Absolute mode Data Range : -134,217,727 to +134,217,727[pulse], Operating speed : Max. 3000[rpm]				
Return to Origin	Origin Sensor, $\pm$ Limit sensor, Z phase (By external encoder)				
GUI	User Interface Program within Windows				
Software	Motion Library (DLL) for windows 2000/XP				

## ● Drive dimension [mm]

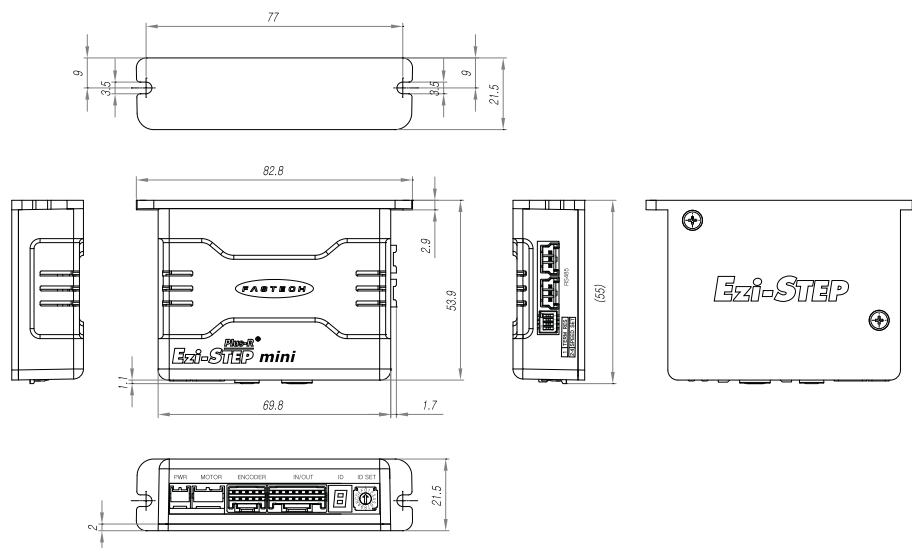

## ● Motor Specifications

M O D E L		UNIT	BM-20M	BM-20L
DRIVE METHOD		----	BI-POLAR	BI-POLAR
NUMBER OF PHASES		----	2	2
VOLTAGE		VDC	2,9	3,25
CURRENT per PHASE		A	0,5	0,5
RESISTANCE per PHASE		Ohm	5,8	6,5
INDUCTANCE per PHASE		mH	2,5	5,0
HOLDING TORQUE		N · m	0,013	0,025
ROTOR INERTIA		g · cm <sup>2</sup>	2,5	5,0
WEIGHTS		g	50	80
LENGTH (L)		mm	28	38
ALLOWABLE OVERHUNG LOAD (DISTANCE FROM END OF SHAFT)	3mm	N	18	18
	8mm		30	30
ALLOWABLE THRUST LOAD		N	Lower than motor weight	
INSULATION RESISTANCE		MOhm	100min. (at 500VDC)	
INSULATION CLASS		----	CLASS B (130°C)	
OPERATING TEMPERATURE		°C	0 to 55	

## ● Motor Dimension [mm] and Torque Characteristics

FASTECH Ezi-STEP Plus-R MINI

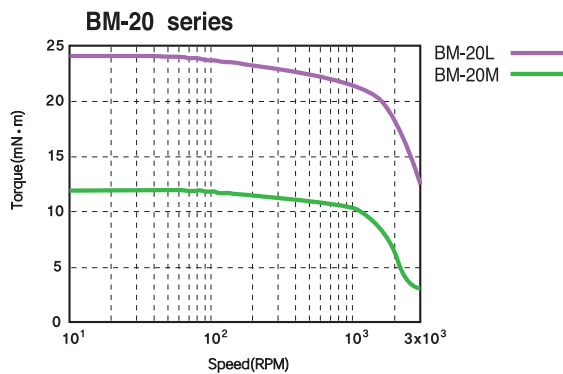
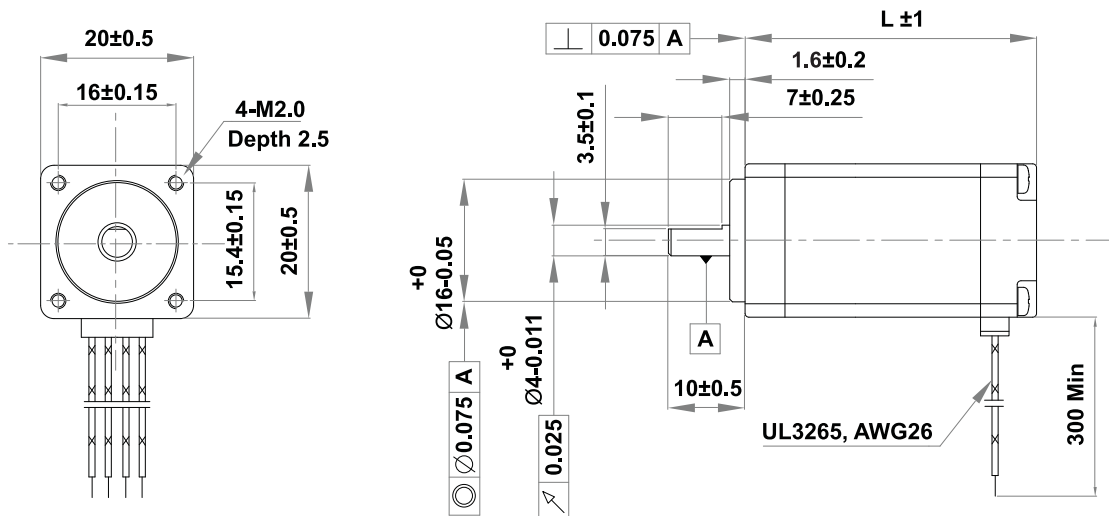

※Measured Condition  
 Motor Voltage = 24VDC  
 Motor Current = Rated Current (Refer to Motor Specification)  
 Drive = Ezi-STEP PR MINI



## ● Motor Specifications

M O D E L		UNIT	BM-25S	BM-25M	BM-25L
DRIVE METHOD		----	BI-POLAR	BI-POLAR	BI-POLAR
NUMBER OF PHASES		----	2	2	2
VOLTAGE		VDC	2.66	9.87	3.654
CURRENT per PHASE		A	0.7	0.21	0.63
RESISTANCE per PHASE		Ohm	3.8	47	5.8
INDUCTANCE per PHASE		mH	2.0	30	5.4
HOLDING TORQUE		N · m	0,033	0,049	0,062
ROTOR INERTIA		g · cm <sup>2</sup>	2	3	7
WEIGHTS		g	55	70	90
LENGTH (L)		mm	23,5	27,5	33
ALLOWABLE OVERHUNG LOAD (DISTANCE FROM END OF SHAFT)	3mm	N	30	30	30
	8mm		38	38	38
ALLOWABLE THRUST LOAD		N	Lower than motor weight		
INSULATION RESISTANCE		MOhm	100min. (at 500VDC)		
INSULATION CLASS		----	CLASS B (130°C)		
OPERATING TEMPERATURE		°C	0 to 55		

## ● Motor Dimension [mm] and Torque Characteristics

- LEAD WIRE
  - HOUSING : 51021-0600
  - PIN : 50079-8000
  - LENGHT : 300mm MIN

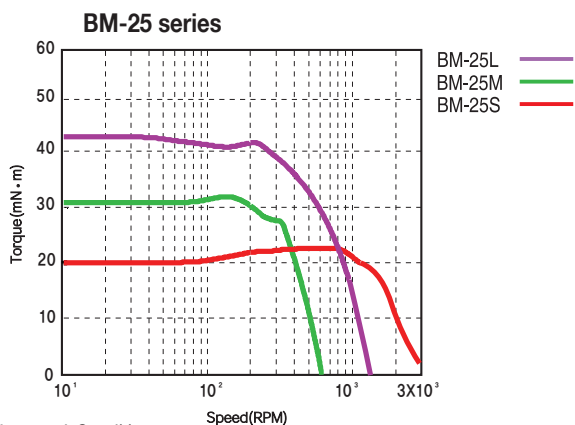
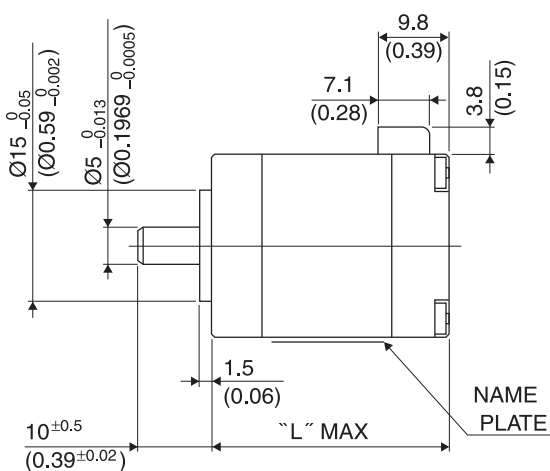
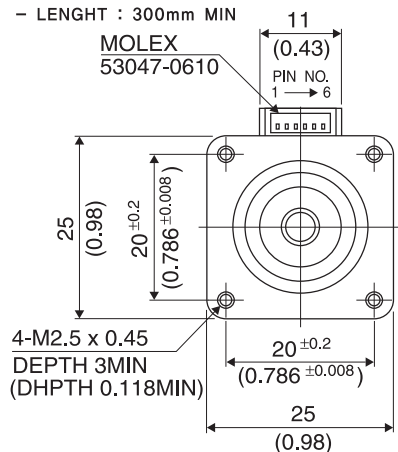

※ Measured Condition  
 Motor Voltage = 24VDC  
 Motor Current = Rated Current (Refer to Motor Specification)  
 Drive = Ezi-STEP PR MINI

## ● Motor Specifications

MODEL		UNIT	BM-28S	BM-28M	BM-28L
DRIVE METHOD		----	BI-POLAR	BI-POLAR	BI-POLAR
NUMBER OF PHASES		----	2	2	2
VOLTAGE		VDC	3,04	3,04	3,42
CURRENT per PHASE		A	0,95	0,95	0,95
RESISTANCE per PHASE		Ohm	3,2	3,2	3,6
INDUCTANCE per PHASE		mH	2,0	5,0	5,8
HOLDING TORQUE		N · m	0,065	0,08	0,11
ROTOR INERTIA		g · cm <sup>2</sup>	9	13	18
WEIGHTS		g	110	140	200
LENGTH (L)		mm	32	45	52
ALLOWABLE OVERHUNG LOAD (DISTANCE FROM END OF SHAFT)	3mm	N	30	30	30
	8mm		38	38	38
	13mm		53	53	53
ALLOWABLE THRUST LOAD		N	Lower than motor weight		
INSULATION RESISTANCE		MOhm	100min, (at 500VDC)		
INSULATION CLASS		----	CLASS B (130°C)		
OPERATING TEMPERATURE		°C	0 to 55		

## ● Motor Dimension [mm] and Torque Characteristics

FASTECH Ezi-STEP Plus-R MINI

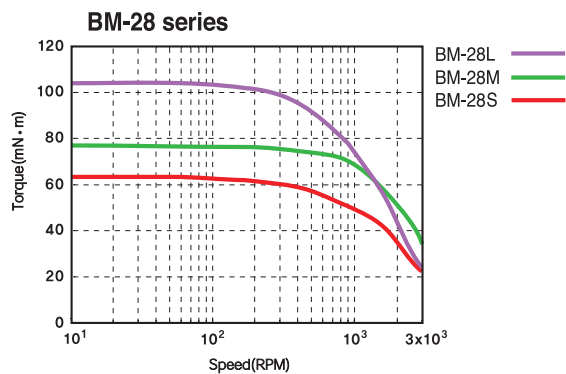
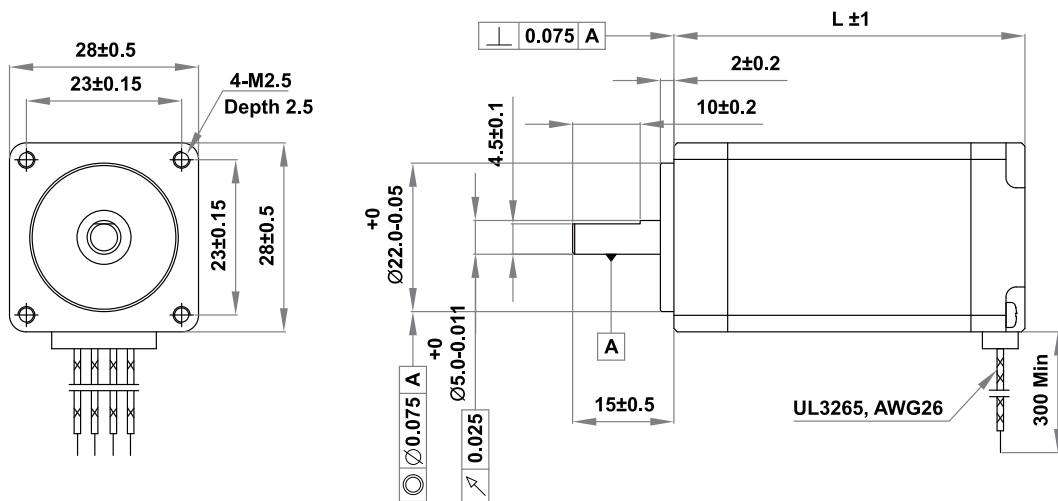

※ Measured Condition  
 Motor Voltage = 24VDC  
 Motor Current = Rated Current (Refer to Motor Specification)  
 Drive = Ezi-STEP PR MINI

## ● Motor Specifications

MODEL		UNIT	BM-35S	BM-35M	BM-35L	BM-35XL
DRIVE METHOD		----	BI-POLAR	BI-POLAR	BI-POLAR	BI-POLAR
NUMBER OF PHASES		----	2	2	2	2
VOLTAGE		VDC	2,28	2,88	4,59	5,39
CURRENT per PHASE		A	0,6	0,6	0,85	0,7
RESISTANCE per PHASE		Ohm	3,8	4,8	5,4	7,7
INDUCTANCE per PHASE		mH	3,2	6,1	6,5	8,4
HOLDING TORQUE		N · m	0,034	0,050	0,176	0,225
ROTOR INERTIA		g · cm <sup>2</sup>	5	8	11	32
WEIGHTS		g	105	120	200	300
LENGTH (L)		mm	22	26	38	535
ALLOWABLE OVERHUNG LOAD (DISTANCE FROM END OF SHAFT)	3mm	N	22	22	22	22
	8mm		26	26	26	26
	13mm		33	33	33	33
	18mm		46	46	46	46
ALLOWABLE THRUST LOAD		N	Lower than motor weight			
INSULATION RESISTANCE		MOhm	100min. (at 500VDC)			
INSULATION CLASS		----	CLASS B (130°C)			
OPERATING TEMPERATURE		°C	0 to 55			

## ● Motor Dimension [mm] and Torque Characteristics

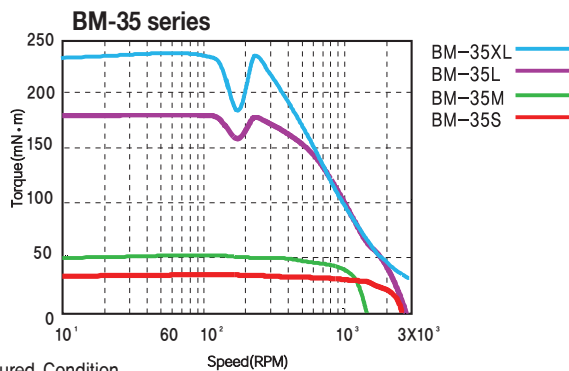
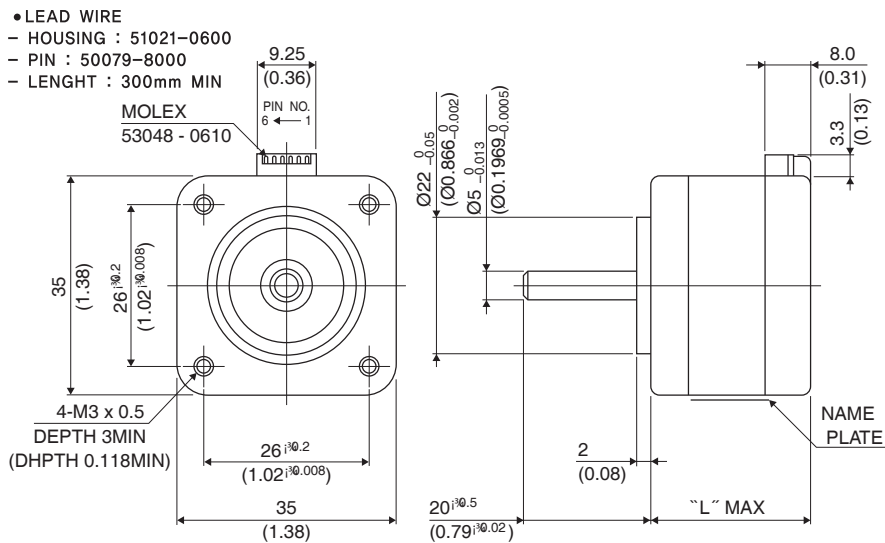

※ Measured Condition  
 Motor Voltage = 24VDC  
 Motor Current = Rated Current (Refer to Motor Specification)  
 Drive = Ezi-STEP PR MINI



## ● Setting and Operating

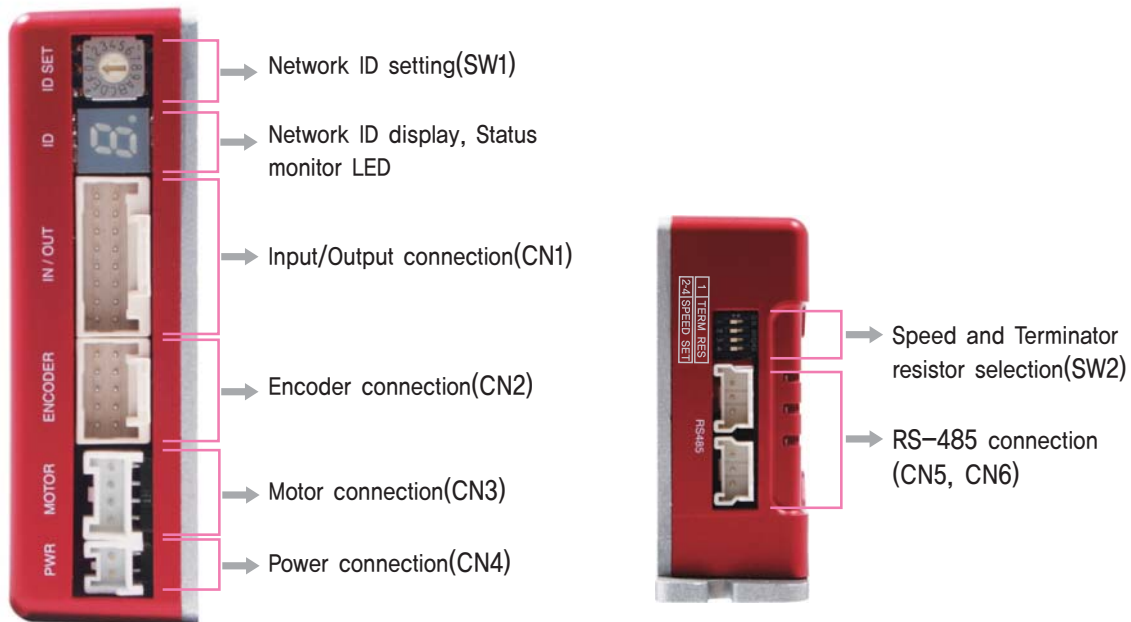

### 1. Protection Functions and 7-Number of Times for Flashed Segment

Times	Protection	Conditions
1	Over current	The current through power devices in inverter exceeds the limit value
2	Over speed	Motor speed exceed 3000[rpm]
3	Step out	Abnormally motor do not followed pulsed input
5	Over temperature	Inside temperature of drive exceeds 55°C
6	Over regenerative voltage	Back-EMF more high limit value*1
7	Motor connect error	The power is ON without connection of the motor cable to drive
9	Motor voltage error	Motor voltage is out of limited value*2
11	System error	Error occurs in drive system
12	ROM error	Error occurs in parameter storage device(ROM)
14	Input voltage error	Power source voltage is out of limited value*3

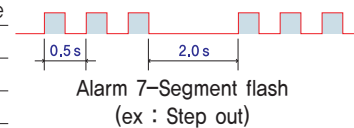

- \*1 : Voltage limit of Back-EMF depends on motor model (Refer to the Manual)
- \*2 : Motor limit voltage value depends on motor model (Refer to the Manual)
- \*3 : Limit value provided to drives depends on driver model (Refer to the Manual)

### 2. Network ID Selection Switch(SW1)

Position	ID number	Position	ID number
0	0	8	8
1	1	9	9
2	2	A	10
3	3	B	11
4	4	C	12
5	5	D	13
6	6	E	14
7	7	F	15



※Maximum 16 axes can be connected in one network.

### 3. Motor Connector(CN3)

NO.	Function
1	B Phase
2	/B Phase
3	/A Phase
4	A Phase

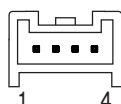

### 4. Speed and Terminator Resistor Selection Switch(SW2)

The purpose of this is to setting the communication speed and connect a terminator resistor if drive is installed at the end of network.

SW 2.1 used for connecting the terminator resistor.  
SW 2.2~SW 2.4 used for setting speed as follows.

SW 2.1	SW 2.2	SW 2.3	SW 2.4	Baud rate[bps]
-	OFF	OFF	OFF	9600
-	ON	OFF	OFF	19200
-	OFF	ON	OFF	38400
-	ON	ON	OFF	57600
-	OFF	OFF	ON	115200*1
-	ON	OFF	ON	230400
-	OFF	ON	ON	460800
-	ON	ON	ON	921600

\*1 : Default setting value

If SW2.1 is OFF, terminator resistor is disconnected.  
If SW2.2 is ON, terminator resistor is connected.

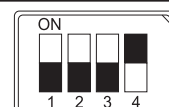

## 5. Input/Output Connector(CN1)

NO.	Function	I/O
1	24VDC	Input
2	24VDC GND	Input
3	BRAKE+	Output
4	BRAKE-	Output
5	+Limit Sensor	Input
6	-Limit Sensor	Input
7	Origin Sensor	Input
8	Digital IN 1	Input
9	Digital IN 2	Input
10	Digital IN 3	Input
11	Digital IN 4	Input
12	Digital IN 5	Input
13	Digital IN 6	Input
14	Digital IN 7	Input
15	Compare OUT	Output
16	Digital OUT 1	Output

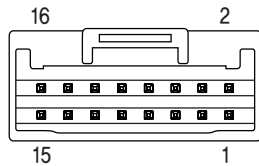

## 6. Encoder Connector(CN2)

NO.	Function	I/O
1	A+	Input
2	A-	Input
3	B+	Input
4	B-	Input
5	Z+	Input
6	Z-	Input
7	5VDC	Output
8	5VDC GND	Output
9	F. GND	----
10	F. GND	----

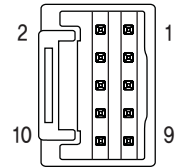

## 7. Power Connector(CN4)

NO.	Function
1	24VDC $\pm 10\%$
2	GND

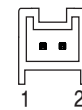

## 8. RS-485 Communication Connector(CN5, CN6)

RS-485 Communication port to connect with Host Controller

NO.	Function
1	+DATA
2	-DATA
3	GND

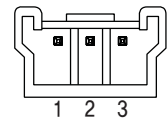

## System Configuration

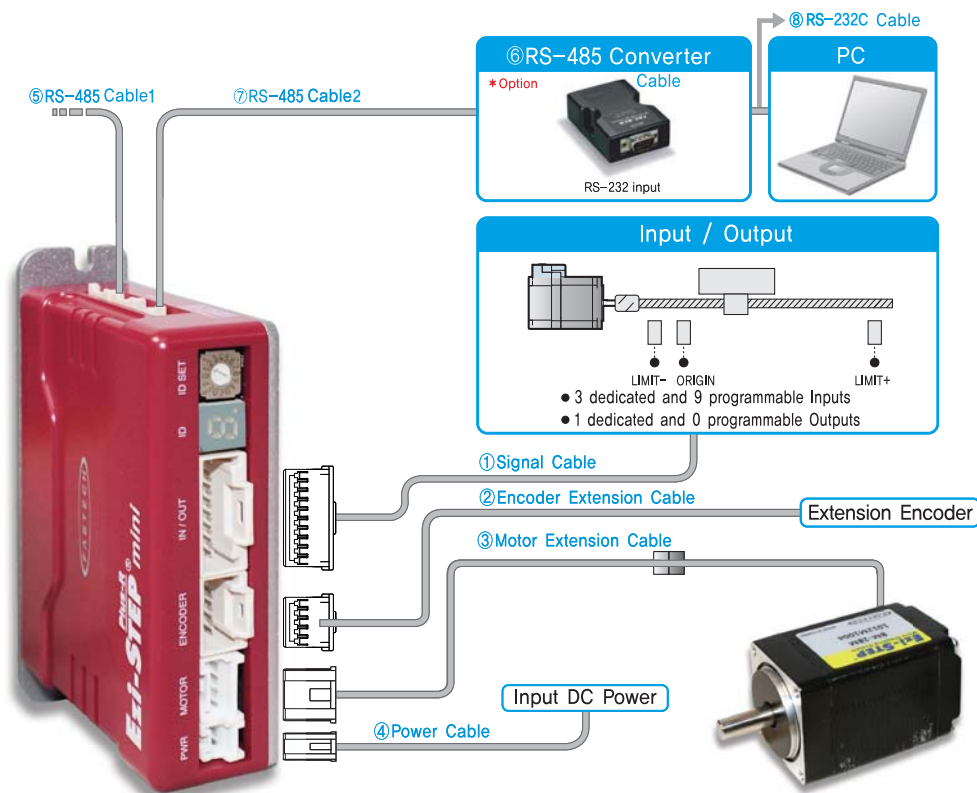

Type	Signal Cable	Encoder Cable	Motor Cable	Power Cable	RS-485 Cable
Standard Length	-	-	30cm	-	-
Max. Length	20m	20m	20m	2m	30m

## 1. Cable Option

### ①Signal Cable

Available to connect between Control System and Ezi-STEP PR MI.

Item	Length[m]	Remark
CSVA-S-□□□F	□□□	Normal Cable
CSVA-S-□□□M	□□□	Robot Cable

□ is for Cable Length. The unit is 1m and Max, 20m length.

### ②Encoder Extension Cable

Available to extended connection between Encoder and Ezi-STEP PR MI.

Item	Length[m]	Remark
CSVI-E-□□□F	□□□	Normal Cable
CSVI-E-□□□M	□□□	Robot Cable

□ is for Cable Length. The unit is 1m and Max, 20m length.

### ③Motor Extension Cable

Available to extended connection between motor and Ezi-STEP PR MI.

Item	Length[m]	Remark
CMNB-M-□□□F	□□□	Normal Cable
CMNB-M-□□□M	□□□	Robot Cable

□ is for Cable Length. The unit is 1m and Max, 20m length.

## 2. Option

### ⑥FAS-RCR (RS-232C to RS-485 Converter)

Item	Specifications
Comm. Speed	Max, 115,2Kbps
Comm. Distance	RS-232C : Max, 15m RS-485 : Max, 1,2km
Connector Type	RS-232C : DB9 Female RS-485 : RJ-45
Dimension	50X75X23mm
Weight	38g
Power	Powered from PC (Usable for external DC5~24V)

### ⑦RS-485 Cable 2

(FAS-RCR to Ezi-SERVO ALL, FAS-RCR to Ezi-STEP ALL, FAS-RCR to Ezi-SERVO Plus-R MINI, FAS-RCR to Ezi-MotionLink)

Item	Length[m]	Remark
CGNA-R-0R6F	0,6	Normal Cable
CGNA-R-001F	1	
CGNA-R-1R5F	1,5	
CGNA-R-002F	2	
CGNA-R-003F	3	
CGNA-R-005F	5	

### ④Power Cable

Available to connect between Power and Ezi-STEP PR MI.

Item	Length[m]	Remark
CMNB-P-□□□F	□□□	Normal Cable
CMNB-P-□□□M	□□□	Robot Cable

□ is for Cable Length. The unit is 1m and Max, 2m length.

### ⑤RS-485 Cable 1

Item	Length[m]	Remark
CGNB-R-0R6F	0,6	Normal Cable
CGNB-R-001F	1	
CGNB-R-1R5F	1,5	
CGNB-R-002F	2	
CGNB-R-003F	3	
CGNB-R-005F	5	

\*Common cable to connect Ezi-SERVO ALL, Ezi-STEP ALL, Ezi-MotionLink and Ezi-SERVO Network

### ⑧RS-232C Cable

Item	Length[m]	Remark
CGNR-C-002F	2	Normal Cable
CGNR-C-003F	3	
CGNR-C-005F	5	

### 3. Connector for Cabling Standard and Manufacturer Information

Usage	ITEM	Specification	Maker
Input/Output Connector (CN1)	Housing	501646-1600	MOLEX
	Terminal	501648-1000(AWG 26~28)	MOLEX
Encoder Connector (CN2)	Housing	501646-1000	MOLEX
	Terminal	501648-1000(AWG 26~28)	MOLEX
Motor Connector (CN3)	Housing	PAP-04V-S	JST
	Terminal	SPHD-001T-P0,5	JST
Power Connector (CN4)	Housing	PAP-02V-S	JST
	Terminal	SPHD-001T-P0,5	JST
RS-485 Communication (CN5, CN6)	Housing	33507-0300	MOLEX
	Terminal	50212-8100	MOLEX

※These connectors are serviced together with purchasing products except when purchasing option cables.  
 ※Above Connectors are the most suitable for Ezi-STEP PR MINI. Another equivalent connector can be used.

### External Wiring Diagram

FASTECH Ezi-STEP Plus-R MINI

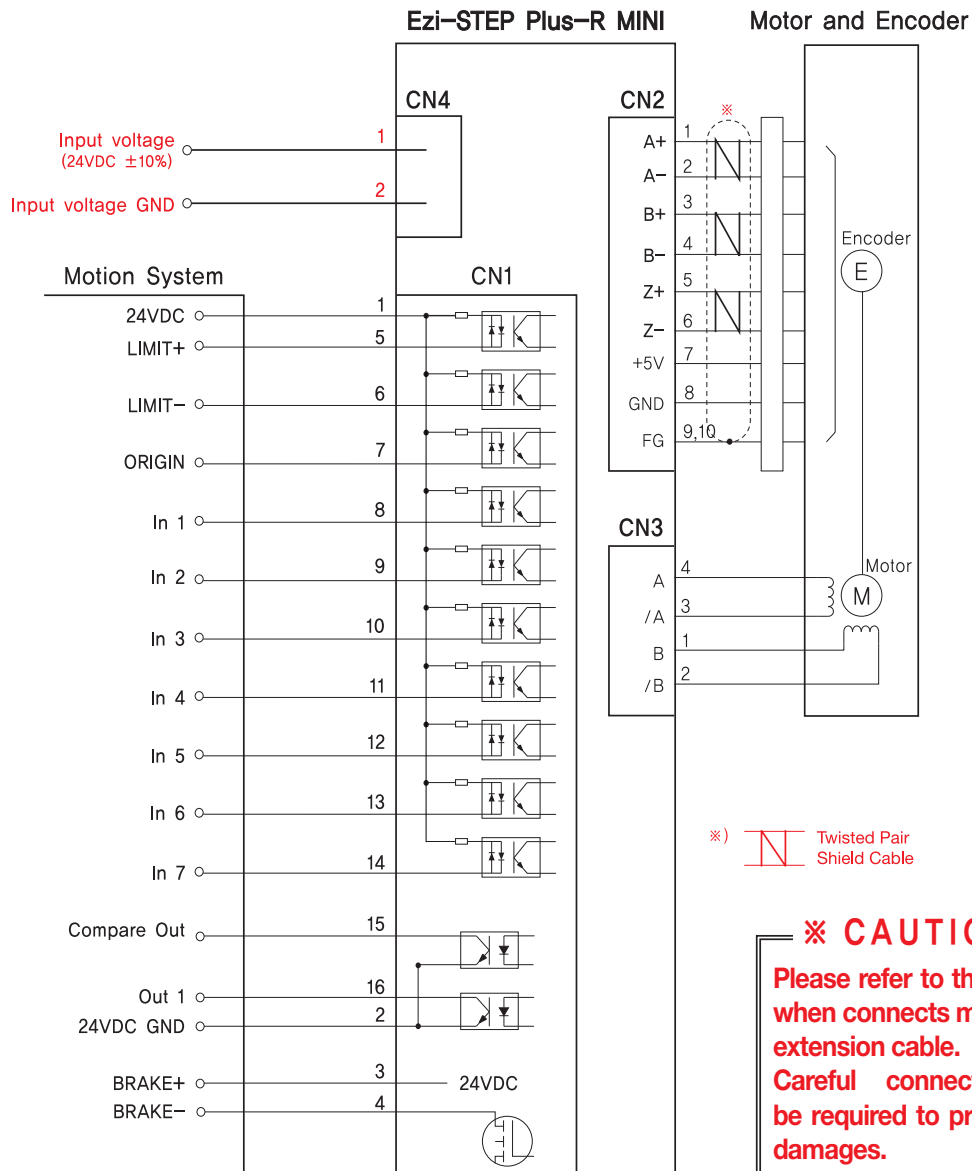



# GUI(Graphic User Interface) Screenshot

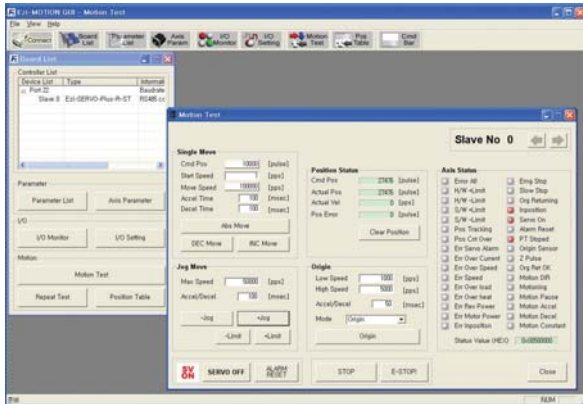

## ◆ Controller Lists and Motion Test

This screen display the controller list that connected to system. You can make a single move, jog and origin command and also the motor status is displayed.

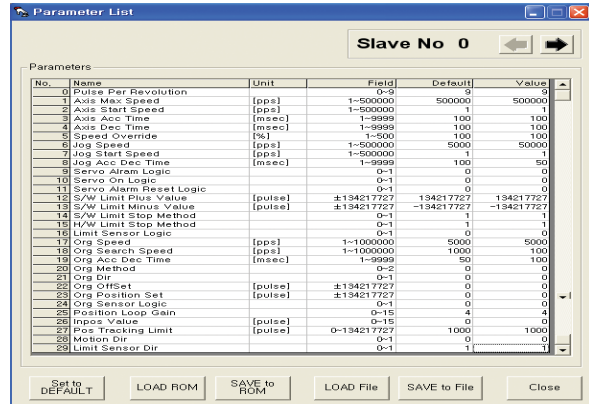

## ◆ Parameter List

All of the parameters are displayed and modified on this screen.

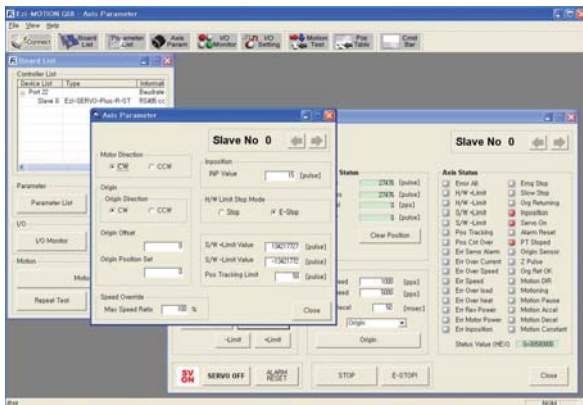

## ◆ Axis Parameter Setup

You can select various parameters that frequently used. (ex : sensor input logic)

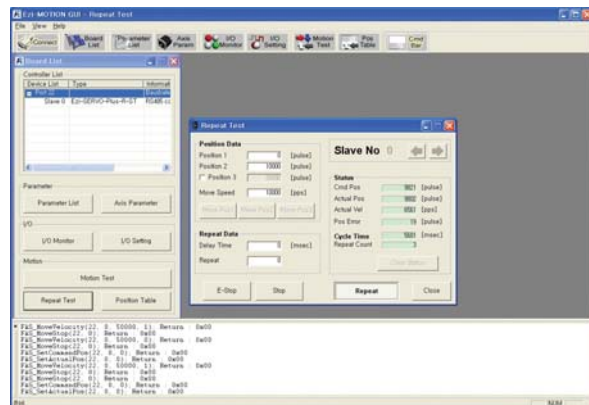

## ◆ Motion Repeat and Monitor Status

Target position, speed, delay time and repeat count are selected for repeat motion test. Motion library(DLL) is also displayed on screen.

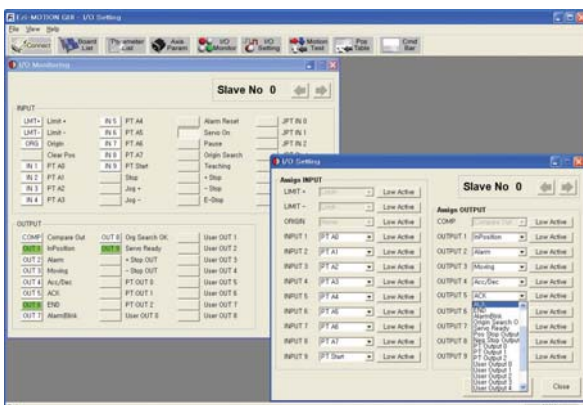

## ◆ I/O Monitoring and Setting

You can select various digital input and output signals of controller.

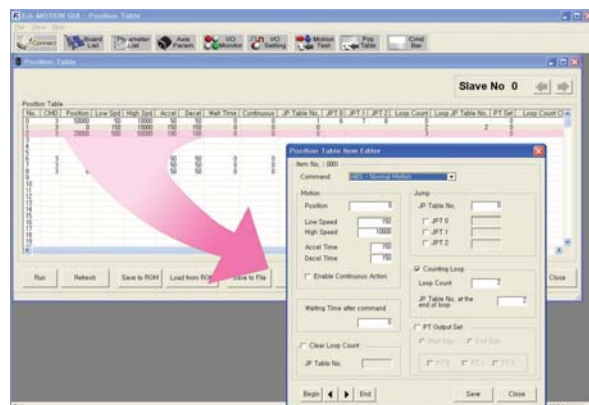

## ◆ Position Table

You can edit the position table and execute it. The position table data can be saved and loaded from Flash ROM and Windows file.



# MEMO

**MEMO**

FASTECH Ezi-STEP Plus-R MINI



*Fast, Accurate, Smooth Motion*

**FASTECH Co., Ltd.**

Rm#1202, 401-dong, Bucheon Techno-Park,  
655, Pyeongcheon-ro, Bucheon-si Gyeonggi-do,  
Republic of Korea (Zip:14502)  
TEL : +82-32-234-6300 FAX : +82-32-234-6302  
E-mail : [fastech@fastech.co.kr](mailto:fastech@fastech.co.kr)  
Homepage : [www.fastech.co.kr](http://www.fastech.co.kr)