

EM-366 BRUSHLESS DC-MOTOR DRIVER 12-48V 30/25A

14.02.2020 366br14

FEATURES

- For BLDC motor with Hall sensor
- Three phase output
- Speed and torque adjustment
- Open/closed loop modes
- Regenerative braking option
- True 4Q-power stage
- Braking resistor output
- Fan control output
- Current limit and trip
- Fault
- Rpm-pulse output option
- Good efficiency
- Low EMC emissions
- DIN-rail mountable

- Firmware 1.4v or later
- Rs-485 Modbus control option

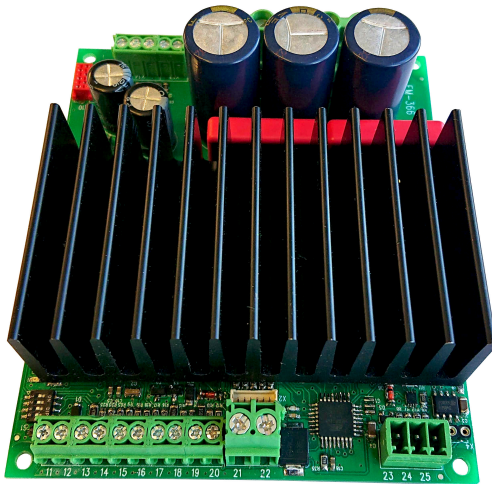

GENERAL

EM-366 is brushless DC-motor driver with hall sensor feedback. The unit has a mosfet power stage with good efficiency and also with industrial EMC requirements. The driver can be used with 120° commutation. This driver has true 4Q power stage, and it makes possible to use regenerative braking. In this braking method the supply voltage rises, this voltage rising can be controlled with braking resistor. If uses battery supply then the braking energy can be leaded back to battery and braking resistor will not needed. The unit has the basic digital command inputs like direction, disable, speed-2 activation and there is analog inputs for speed. Alternatively method to control device is a Rs-485 bus with Modbus protocol. In this way can be easily controlled several units. and current control. EM-366 has PNP output for fault indication use. Some input and output functions can be modified with parameters. Driver includes overvoltage, undervoltage and overtemperature protections. These fault situations are indicated with fault on-board LED. Current limit situations can be reset with reset input, reset-timer or by setting analog speed control to value to 0.

There are two control options for speed. Direct control (open loop) sets motor voltage in proportion to control voltage as with a standard DC-motor. Closed loop uses hall sensor feedback for speed control, this mode offers good speed regulation. Start and stop ramps work in both mode. Speed adjust range, closed loop rpm range and ramps can be set with parameter. Analog input are filtered so that there can also use PWM signal for control speed and current.

Setting can be done digitally with EM-236 interface unit or with Emen-Tool lite program installed in PC and EM-328 adapter cable. Parameters stored into nonvolatile memory of device. This interface unit can also be monitored the current and rpm of motor.

Device can be installed in DIN-rail base and some enclosure options are also available.

TECHNICAL DATA

Supply voltage 12-48Vdc (11-58Vdc)
 Overvoltage shut down 60V
 Idle current typ. 30mA
 Max current 30A cont. (@ 24Vdc, Tamb. 40 °C)
 Max. current 25A cont. (@ 48Vdc, Tamb. 40 °C)
 Max current peak 60A (max 2s)
 Max brake output current 10A
 Pwm frequency typ. 16kHz
 Overtemperature Temp shut down 90 °C
 Current limit setting 1-60A (step 1A)
 Current limit analog scale 0-5V = 0-60A
 Logic level of digital inputs
 "off" = 0-1V or open / "on" = 4-30V
 Input impedance of logic inputs 10k
 Response time of digital input 2ms
 Analog input range 0-5V up to 0-10V
 Input impedance of analog inputs 100k
 Input filter of analog input 100Hz
 Fault outputs NPN max 50mA (5V / 12V)
 Fan output NPN max. 100mA (12V)
 Fan output "on" > 55 °C / "off" < 50 °C
 EMC measured for industrial and env.
 PCB material flammability class UL94V-0
 Dimensions 108x91x37mm
 Weight 270g

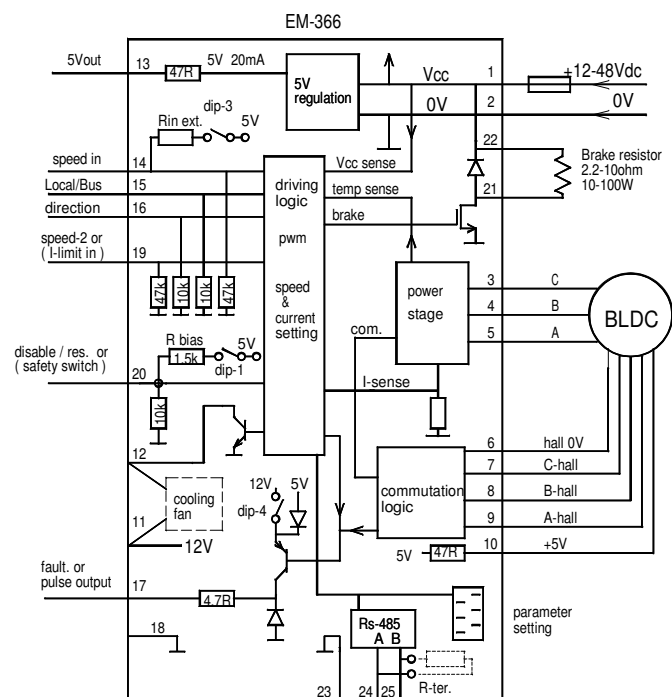

ELECTROMEN Oy

www.electromen.com

TAKE IN USE

Operating voltage 12-48Vdc ripple less than 20%
An external supply fuse is recommended (2-50A)

Be sharp when connect motor wires, because there is lot of combination. If motor takes much current or run roughly then change wiring.

Default settings are in brackets in parameter list. These are good start-up values

In example picture beside there all input connected, but device work also with less wiring. So connect only needed functions.

Fault outputs are PNP type, and pull up when activates,

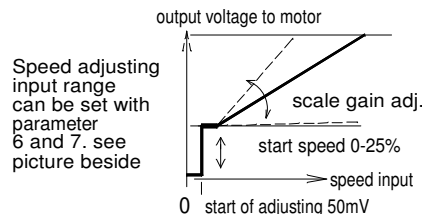
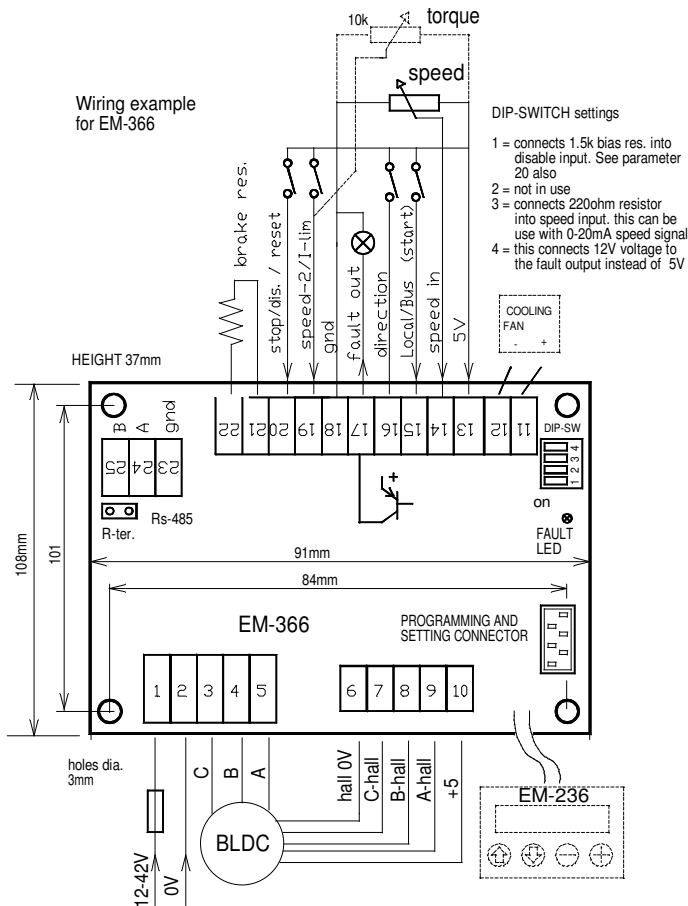

In some application load can be generated energy back to drive, when slowing down speed. Then there needed braking resistor, which absorbed extra energy. NOTICE that the parameter 18 has to be set about 10% higher than unloaded voltage of power supply. If uses battery supply, then braking resistor would not needed.

CONTROL INPUTS

SPEED input is a analog control input for speed setting. Set signal can be between 0-5V and 0-10V
Speed scaling can be made with parameter 6 and 7.

LOCAL/BUS This input can be used to select control source
Local control with card terminal or Bus control with Rs-485
This Input options can be set with parameter 11
This input works also as start/stop input if param 11 = 3

DIRECTION input is a digital input. It changes the rotation direction. It uses automatically stop/start ramps during change.

SPEED-2 / I-LIMIT is a multifuntion input. Normally this input is a PNP digital input, which activate speed-2 presetting, which has been set with parameter 13.
If parameter 12 is set = 0, then this input changes to analog input for current limit setting, 0-5V reponds lim. value 0-60A
If parameter 12 is set = 1, then input work as stop input

DISABLE / SAFETY SWITCH input is a multifuntion input. Normally it works as an digital input, "high" will disable driver and motor goes to freewheeling (disables = all poles floating). This input has highest priority!

This input can be set to work as an safety switch input with line monitor. see picture beside
This option can be set with param. 20. Safety switch conneted GND to pin 20, and with dip-switch-1 will activate bias resistor for line monitoring.

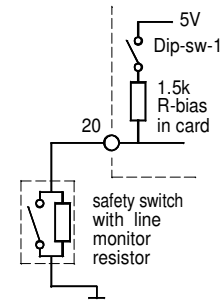

OUTPUTS

FAULT / PULSE OUT This output modes can be set with parameter 16. There is some options when output will be activate. The special mode is pulse output, in this case output gives out rpm-pulses which can scaled with parameter 17

BRAKE output can used to control magnetic brake of motor or switch a braking resistor in regenerative braking. the mode can be set with parameter 19

FAN output pin 12 pull down if temp exceed 55 °C

Rs-485 port can be used to control device with Modbus protocol
This port has own guige sheet " Modbus register definitions for EM-366"

MONITOR VALUES

1. current 1A / digit
2. braking current 1A / digit
3. hall sensor freq. 0-255Hz
4. operation voltage 0.1V / digit
5. pwm 0-255 (255 = 100%)

INDICATIONS.

Continuous light: Over. temp. or over voltage or disable
Fast blinking : current limit exceeded
Short blinks: shutted down by overcurrent (I-trip)
Long blinks: safety switch wire fault
Slow blinking: shutted down by safety switch

Fault output: (Pin-17 PNP open collector output)
Overtemperature, Overvoltage, Undervoltage.
This indicates also I-Trip if parameter 16 is set to = 0

SETTABLE PARAMETERS (prog. 366 v1.4)

EM-356A parameters set with interface unit EM-236A or with Ementool-Lite and EM-328

1. mode: open loop =0 / closed loop=1 (0)
2. closed loop range 0-4 (3)
0=30000rpm
1=15000rpm
2=9000rpm
3=5000rpm
4=3000rpm
3. start ramp 0-5s / 0-50 (1s)
4. stop ramp 0-5s / 0-50 (1s)
5. I-trip delay 1-255ms / 0-255 (0=no trip (200ms)
6. scale start speed 0-25.5% / 0-255 (0)
7. scale gain 0-2.55 / 0-255 (200)
8. closed loop dynamic P-factor 1-200 (10)
or open loop mode Rxl load compensation
9. closed loop dynamic I-factor 1-200 (10)
10. regen. braking current limit 2-60A / 2-60 (25)
11. Local/Bus select input pin-15 options (0)
0 = open or "low" = Local / "high" = Bus
1 = open or "low" = Bus / "high" = Local
2 = Local/Bus control selection with Bus only
3 = Local mode only / pin 15 as start
12. current limit 0 / 1-60A / 1-60 (20)
0= current setting with I-lim input pin 19
1-60 = current limit
13. speed-2 value 0-100% / 0-100 (50)
14. I-trip reset mode (0)
0= only with disable pin
1= disable or with speed input change 0 to up
10-200 = timer reset with 0.1s steps = 1-20s.
15. Over temp. reset mode (0)
0= only with disable input
1 = with speed input change 0 to up
10-200 = timer reset 0.1s steps = 1-20s.
16. Indications of fault output pin 17 (0)
0 = overtemp. and overvoltage
1 = overtemp, overvoltage, and I-trip
2 = overtemp, overvoltage, I-trip and overcurrent
3 = reserved for pulse output use, see param 17
17. pulse output divider, enabled only if param. 16=3 (1)
1 = 1pulse/round
2 = 1pulse/ 2round...
...
20= 1pulse/ 20round
18. brake res. threshold (=overvoltage) 15-60V / 15-60 (50)
19. brake output mode and braking mode 0-3 (1)
0 = output active if param. 18 value exceed and brk. mode "regenerative"
1 = output active if param 18 value exceed and brk. mode "freewheel"
2 = output active when "run" and braking mode "regenerative"
3 = output active when "run" and braking mode "freewheel"
20. Disable / safety switch input options
0 = disable (and reset)
1 = safety switch stop with wiring monitor (closing contact)
21. Baud rate 0...5 (0)
0= 9600, even, 1 stop, 3= 19200, even, 1 stop
1= 9600, odd, 1 stop 4= 19200, odd, 1 stop
2= 9600, none, 2 stop 5= 19200, none, 2 stop
22. Modbus Address 1...247 (1)