

DC-MOTOR CONTROLLER

EM-362 12-24V 160A

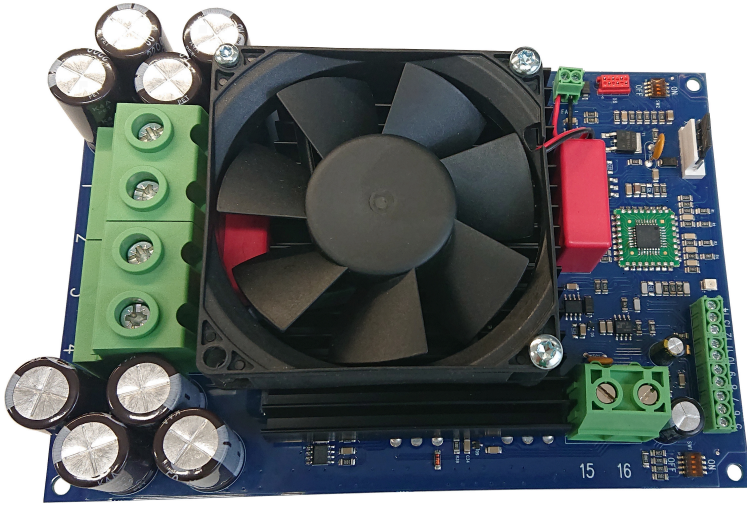

FEATURES

- high current output
- brake load output
- recommended motor up to 1.8 kW at 12V and 2.7 kW at 24V
- current limit
- current limit for brake also
- zero-current limit
- speed setting/adjustment
- flexible control inputs
- impulse / continuous mode
- rail base mountable
- digital parameter setting
- 2/16kHz pwm freq. options

APPLICATIONS

- vehicles
- winches
- steering prop

EM-362 is a full bridge DC-motor starter. It is designed to work with low voltage DC-motors (permanent magnet and brushed) in applications where a variety of special functions and settings are needed. Starter has adjustable acceleration and deceleration ramps, enabling the smooth starts and stops. Adjustable current limit protects the motor against overcurrent. Current limitation for braking is also available (regeneration I-limit). This driver is specifically designed for 12/24V applications, but it's still able to function when voltage is dropped down to 8V. The driver also has an integrated cooling fan, which improves cooling at continuous driving.

EM-362 has two selectable and settable speeds. This feature can be useful eg. in positioning applications. The FW and BW -inputs control the forward and backward runs. STOP input is used to stop the motor, but individual limit inputs are also available for FW and BW direction end stops, that will cause a motor shut-down. SPEED-2 input activates the presetable speed-2, but it can also be set for use as an analog speed control input (0-5V signal). FAULT terminal operates same time as an input and output. Fault line is internally pulled high (100kohm to Vsupply), but will be pulled down in overheat or conditionally also in current trip situation. If FAULT-line is pulled down externally it will cause a stop and disable a new start. For example it is possible to link FAULT pins of several units together and achieve a synchronous stop this way.

Driving can be done with two selectable control modes, continuous and impulse. In continuous mode the motor runs as long as the command is on. In impulse mode a short command starts the motor, and only a new impulse will change the status. Inputs are divided into two groups, command and limit -inputs. These groups can be individually set to work with NPN (connect to zero control) or PNP (positive voltage control) -logic. The parameters are set digitally with a handheld EM-236 interface unit. With this unit the same settings (adjustments) can also be easily copied to multiple devices. Operation of the controller and some of its functional values can also be monitored with EM-236 interface unit.

TECHNICAL DATA (prog. EM-362C v1.0)

Supply voltage nom. 12-24Vdc (abs. limits 8-32Vdc)
 Shutdown voltage 7.5V (start up 9.5V)
 Overvoltage limit adjustable 15-40V
 Idle current typ 20mA
 Motor current max. cont. 160A (at 50° amb temp)
 Motor current max. 30s. 200A (at 50° amb temp)
 Motor current and peak 300A (5s at start)
 Currents output capability is about 30% lower at 16kHz pwm freq.
 Braking load current (pin 16) max cont 50A peak 100A
 Current limit adjustable 1-255A
 NOTICE! current limit is 50 % boosted during start ramp.
 Over temp. limit 100°C
 Start and stop ramp adjustable 0-5s
 PWM frequency 2kHz / 16kHz
 Speed input scale (pin 9) 0-4.5V = 0-100% pwm
 Speed input scale in mA mode 0-18mA = 0-100%
 Speed input impedance in mA mode 250ohm.
 I-lim input scale 0-5V = 0-250A
 Input control logic: high =4-30V, low=0-1V
 Control input impedances typ. 10kohm
 Control input response time typ 5ms.
 Fault out. NPN open coll. max 30V / 0.5A
 Fault in. activates Uin < 1V (NPN with 100k pull up)
 Fault output ext. pull up res. 2.2k/5V or 2.2k/12V
 Fan-output switch on 55°C, off 50°C
 Heat losses 40W at 100A and 90W at 200A (2kHz)
 40W at 70A and 90W at 140A (16kHz)
 Integrated 12V Fan, typ. 100mA
 Motor and supply connectors 25mm²
 Control connectors 1mm²
 Dimensions 180x122x60mm
 CE-tested for industrial environment (EMC)
 Operating ambient temp (Ta) -40...60°C
 Weight 620g

EM-362 BLOCK DIAGRAM

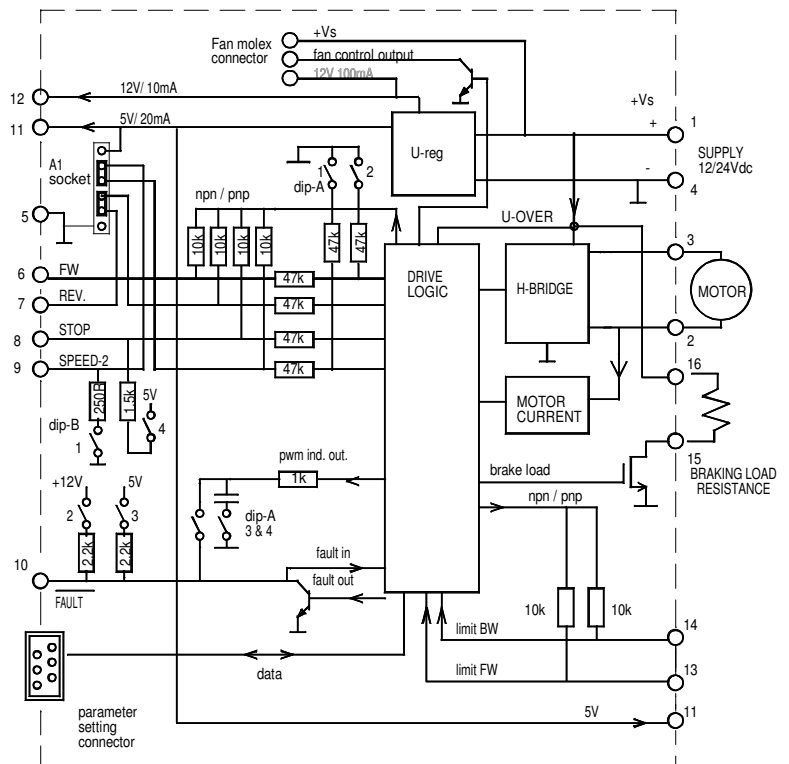

Supply voltage must be filtered DC of 12-24V, and ripple should be less than 20% at full load.
CAUTION ! Wrong polarity can damage the unit.
CAUTION ! Unit doesn't have an internal fuse. So if required, an external fuse should be added. **NOTICE!**
 thermal controlled FAN-out only in PCB ver3 or more advanced.

ADJUSTMENT AND SETTINGS (prog. EM-362 v.1.0)

Settings can be done with 3 interface device options.

1. EM-236 interface unit.
2. EM-328 series interface units with EmenTool Lite PC-software.
3. EM-326 interface unit with EmenTool App smartphone application. If using App, you can set a device-specific access code, which protects the device against unauthorized smartphone connections.
 The access code can be reset with simultaneous FW and BW command, when power is switched on.

SETTABLE PARAMETERS (EM-362 v1.0 defaults in brackets)

- 1 Command mode: continuous = 0, impulse= 1 (0)
- 2 Start condition combinations: 0-3 (1)
 0= start both direction after I-trip and Stop
 1= start only opposite direction after I-trip
 2= start only opposite direction after Stop
 3= start only opposite direction after I- and Stop
- 3 Input logic combinations 0-7 PNP/NPN (0)
 PNP control with positive signal and input has pull down res.
 NPN control with negative signal and input has pull up res.
 N.C. = input resistor as above, but control signal is inverted
 0= cont. PNP, limits PNP 4=cont. PNP, limits PNP N.C.
 1= cont. NPN, limits PNP 5=cont. NPN, limits PNP N.C.
 2= cont. PNP, limits NPN N.C. 6=cont. PNP, limits NPN
 3= cont. NPN, limits PNP N.C. 7=cont. NPN, limits PNP
- 4 Running speed-1: 0-100% / 0-100 (100)
- 5 Running speed-2: 0-100% / 0-100 (50)
 Note: If selected to 0 "speed-2 input" is used as analog 0-5V speed control input.
 Note2: If selected to 1 "speed-2 input" is used as analog 0-5V speed control input, and run start automatically and REV. input changes direction
- 6 Current limit : FW 0-255A / 0-255 (30)
- 7 Current limit : BW 0-255A / 0-255 (30)
NOTICE! if both 6 & 7 is set = 0, then I-lim input is active
- 8 Trip combinations: 0-3 (1)
 0= No I-trip, no zero-current-trip
 1= Only I-trip
 2= Only zero-current-trip
 3= Both I-trip and zero-current-trip
- 9 I-trip delay: 0-255ms / 0-255 (20)
- 10 Fault output combinations: 0-5 (1)
 0= I-trip and zero current won't cause fault output signal
 1= Only I-trip causes fault output signal
 2= Only zero current causes fault output signal
 3= Both I-trip and zero current causes fault output signal.
 4= Overcurrent indication
 5= "Run" indication = pull down when motor runs

FAULT-LED signal codes

1. power on one blink
2. current on limit led is lit
3. current trip fast blinking...
4. zero-cur trip long blink- short pause...
5. over voltage 4 x blink -pause...
6. over heat short blink- long pause...
7. time-out 3 x blink + long blink...
8. fault input 2 x short + 1x long blink...

MONITORABLE VALUES (EM-236 / EmenTool)

1. PWM-level-% 0-100% (0-100)
2. Hour counter (max.65535h)
3. Start counter (max.65535)
4. Carry counter for start counter
5. Braking current 0-400A (0-400)
6. Motor current 0-400A (0-400)
- 11 Overvoltage limit: 15-40V / 15-40 (30)
 Overvoltage can be caused by load driving the motor or when braking the speed down, but supply can not accept the current back from driver. Exceeding the limit will cause the brake load to switch on. If the voltage still rises 10% of the limit value, the power stage is set to free-wheel state. With a direct battery supply the brake current is charging the battery and voltage will not normally rise.
- 12 Load compensation: 0-255 / 0-255 (0)
 Load compensation (Rxl) improves low speed and start torque, but too high compensation will result in unstable running. Run motor at low speed (30%), then increase compensation with small steps until motor starts to behave unstably, then decrease value for about 10%.
- 13 Timeout: 0-255s. / 0-255 (0=not in use) (0)
- 14 Reset for start and hour-counter 0/1 (0)
 select 1 and push save = reset counters
- 15 Start ramp: 0.2-5s / 0-500 (100)
- 16 Stop ramp: 0.2-5s / 0-500 (100)
- 17 Start kick 0-200ms / 0-200 (0)
 Gives short 0-200ms full drive pulse for start.
- 18- I-trip auto reversing 0-5s / 0-500 (0)
 Automatically change run direction when I-trip occurs, the reversing time will be selected with this parameter.
- 19- Freewheel options 0-5 (0)
 0= Freewheeling when overvoltage.
 1= Freewheeling when overv. or stopped.
 2= Freewheeling when overv. or during stop ramp.
 3= Freewheeling when overv. or when stopped or during stop ramp.
- 20- Pwm frequency 1=2kHz / 2=16kHz
- 21- Current limit in braking 5-255A / 5-255 (50)
- 22- Pin-15 (brake load) options 0-2 (0)
 0= Regen. braking = switch on when overvoltage exceed.
 1= Running indication = switch on pin-16 when motor runs.
 2= As above but also stop input switch on pin-16.

