

EM-347A BRUSHLESS DC-MOTOR DRIVER 12-36V 55A

EM-347A-fan 12-36V 70A

FEATURES



- To the motors with HALL sensors
- Three phase output
- Speed and torque adjustment
- Open/closed loop modes
- Dynamic braking
- Control output for cooling fan.
- True 4Q-power stage
- Braking resistor output
- Selectable brake mode
- Current limit and trip
- Symmetrical control option $\pm 5V$ or $\pm 10V$
- Fault and overcurrent outputs
- Good efficiency
- Low EMC emissions
- DIN-rail mountable
- Rpm-pulse output option
- A-version has 20% improved output current
- A-version available with integrated fan
- Firmware v1.4 extended control opt. par. 11
- Firmware v1.9 options added to par. 14 and 17

GENERAL

EM-347A is a brushless DC-motor driver with hall sensor feedback. The unit has a mosfet power stage with good efficiency and it meets today's EMC requirements. The driver can be used with 120° commutation. This driver has true 4Q power stage, which makes it possible to use regenerative braking. In this braking method the supply voltage rises, but voltage rising can be controlled with a braking resistor. If using battery supply, then the braking energy can be lead back into the battery and a braking resistor will not be needed. The unit has basic digital command inputs like direction, brake, start/stop, disable and there are analog inputs for speed and current control. One digitally presettable second speed (speed-2) is possible to activate with digital command input. EM-347-48V has two NPN outputs for fault and overcurrent indication use. Some input and output functions can be modified with parameters. Driver includes overvoltage, undervoltage and overtemperature protection. These fault situations are indicated with fault on-board LED. Overtemperature and current limit situations can be reset with reset input, reset-timer or by setting analog speed control to value to 0.

There are two control options for speed. Direct control (open loop) sets motor voltage in proportion to control voltage as with a standard DC-motor. Closed loop uses hall sensor feedback for speed control. This mode offers good speed regulation. Start and stop ramps work in both modes. Speed adjust range, closed loop rpm range and ramps can be set with parameters. Analog inputs are filtered so that they can also use PWM signal for controlling speed and current.

Settings can be done digitally with EM-236 interface unit or with Emen-Tool lite program installed in PC and EM-268 adapter cable. Parameters are stored into non-volatile memory of device. This interface unit can also monitor the current and rpm of motor. If necessary, the device also has an optional cooling fan available, which can be controlled with its designated output. This output switches on fan, when temperature rises over 65 deg.

The device can be installed in DIN-rail base and some enclosure options are also available.

TECHNICAL DATA

Supply voltage 12-36V (11-42Vdc)
 Overvoltage limit 15-65V (adjustable)
 Idle current typ. 30mA
 Max current 55A cont. (Tamb. 50 °C)
 Max current 70A cont. with fan cooling
 Max current peak 100A (max. 5s)
 Max brake output (pin-21) current 25A
 Brake resistor recom.value 1-10ohm
 Pwm frequency typ. 16kHz
 Overtemperature shut down 90 °C
 Fan output switch on > 65 °C
 Current limit setting 1-100A (step 1 A)
 Current limit analog scale 0-5V = 0-100A
 Logic level of digital inputs
 "off" = 0-1V or open / "on" = 4-30V
 Input impedance of logic inputs 10k
 Response time of digital input 2ms
 Analog input range 0-5V up to 0-10V
 Input impedance of analog inputs 100k
 Input filter of analog input 100Hz
 Overcur. and fault outputs NPN max 50mA
 Output for fan cooling 12V max. 100mA
 EMC measured for industrial environment
 PCB material flammability class UL94V-0
 Dimensions 140x122x50mm
 Weight 650g

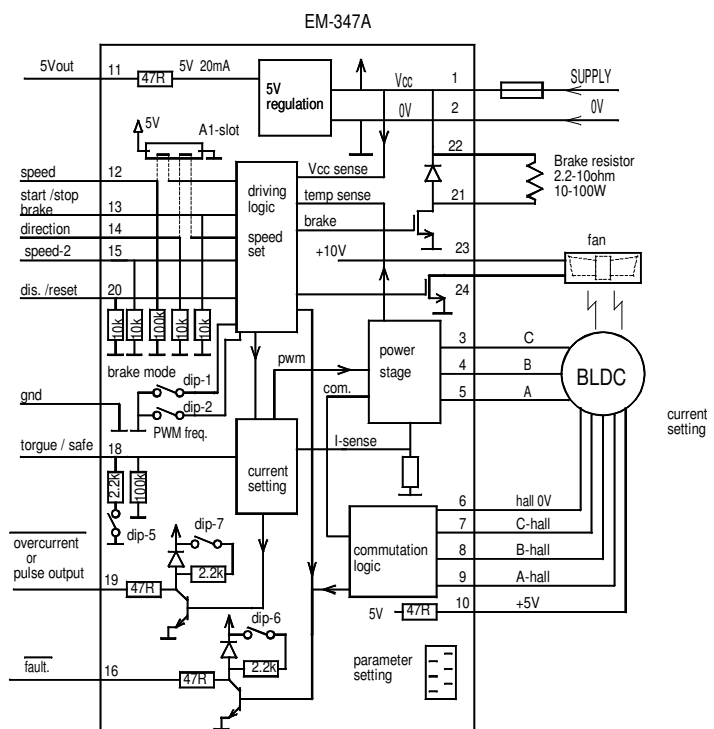

TAKE IN USE

Nominal supply voltage is 12-36Vdc, ripple repetitive peak max.63V.
An external supply fuse is recommended (10-75A).

Pay attention when connecting motor wires, because there are a lot of combinations.
If motor takes much current or runs roughly, then change wiring.

Default settings are in brackets in the parameter list. These are good start-up values.

Current limit has two mode, I-trip means overcurrent shutdown and the motor shutdown when current limit is exceeded or optionally continuous current limitation mode, when current is only limited, this last mode I-trip is disabled with parameter 5

In example picture to the left, all inputs are connected, but the device also works with less wiring. So only connect needed functions.

In high power applications, a DC-fan can be installed into driver to improve cooling. Driver has its own connector for fan. This output offers regulated DC- voltage (12V). This output will activate when driver temperature exceeds 65°C.

Speed adjusting input range can be set with parameters 6 and 7. See picture below. In closed loop mode the speed range setting done with parameter-2. These rpm range values are calculated for 2-pole motor, for example 8-pole motor the rpm ranges are 4-time smaller.

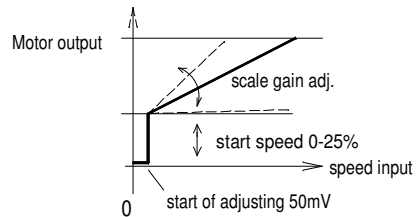

A1-CARD

If symmetrical control is needed ($\pm 5V$ or $\pm 10V$), then an EM-A1 auxiliary card can be added into A1 slot. In symmetrical control the rotation direction determined by the polarity of the control signal and the middle point (0) is same as STOP. The installing of EM-A1 modified inputs:
SPEED input 0-5V / 0-10V changes to $\pm 5V$ or $\pm 10V$ input. DIRECTION input changes to -5V output. This voltage can be used for potentiometer, see drawing. Instead of a potentiometer, a symmetrical voltage signal can also be used.

STOP and BRAKE

Driver has two options a brake motor. First option uses stop ramp and regenerate energy back to driver during slowing down. In this mode the regenerating energy has to lead battery or braking resistor. If there is battery power supply then energy goes automatically back to the battery. But in power supply use there has to use braking resistor, its output is activated when voltage exceeds value which has set with parameter-18, recommended set value is 10% over unloaded supply voltage. The second option is dynamic brake which means that stop ramp by-passed and motor poles shorted, this offer quick stop, but current can be rise very high braking, so this is NOT RECOMMENDED for braking in cases where motor has high inertia! Braking options can be selected with parameter 11 and 13

CONTROL INPUTS and OUTPUTS

Speed input is an analog control input for speed setting. Signal can be set between 0-5V and 0-10V. Speed scaling can be done with parameters 6 and 7.

Torque input is an analog input for current limit setting. 0-5V signal to 0-100A current. This input can be set to work as analog input when parameter 12 is set =0.

Start/stop input can be used start and stop and brake motor. Parameter 11 can be set different start and stop options. Stop means that motor stops with stop ramp. Brake means that motor stops quickly with dynamic brake. This input can be set work also as FW-start. Input functions can be set with parameter 11.

Direction input is a digital input. It will change the rotation direction. It uses stop/start ramps during change. This input can set also as BW-start input, see param. 11

Speed-2 input is a digital input that activates speed-2. Speed-2 input can be used also as stop in this input function can be set with parameter 13

Reset /disable input is a digital input, that disables the driver. Motor goes to freewheeling (all poles floating). This input can also be set to work as reset with parameters 14 and 15. This input has the highest priority.

INDICATIONS LED and OUTPUTS

Fault led:
Fast blinking = I-trip or overvoltage
Random blinking = current limit, braking current limit
Continuous = overtemp, disable input "on", undervoltage

Fault output: (Pin-16 NPN open collector output) this activates with general fault, Overtemperature, Overvoltage, Undervoltage. but this output can also indicate I-Trip if parameter 16 is set to = 0

Overcurrent output : (pin-19 NPN open collector out)
This output indicates when current limit is exceeded, but this output can be set also indicate I-trip situation or work as rpm pulse output.
This output set with parameter 17

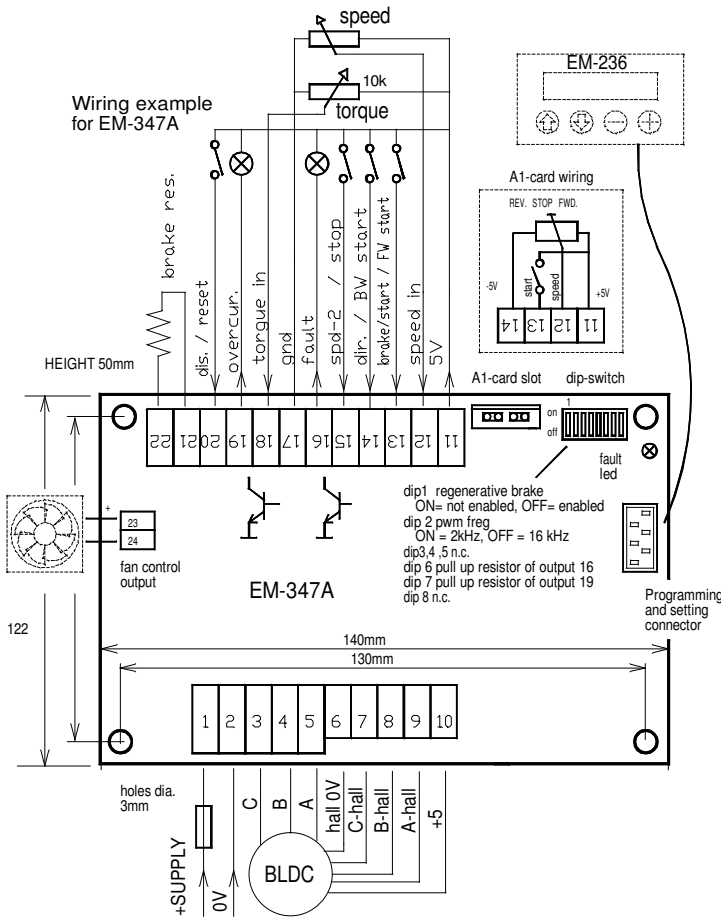

SETTABLE PARAMETERS (prog. 347 v1.9)

EM-347 parameters are set with interface unit EM-236 or with Ementool-Lite and EM-268.

1. Mode: 0-2 (0)
0= open loop
1= closed loop
2= closed loop " high inertia "
2. Closed loop range 0-4 (3)
0=3000rpm 2=9000rpm 4=3000rpm
1=15000rpm 3=5000rpm
3. Start ramp 0-5s / 0-50 (1s)
4. Stop ramp 0-5s / 0-50 (1s)
5. I-trip delay 0.01-2.5s / 0-255 0=no trip (0.2s)
6. Scale start speed 0-25.5% / 0-255 (0)
7. Scale gain 0-2.55 / 0-255 (200)
8. Closed loop dynamic P-factor 1-200 (10)
9. Closed loop dynamic I-factor 1-200 (10)
10. Braking current limit 10-50A / 10-50 (50)
11. Pins 13 and 14 input mode 0-4 (1)
0=Stop / start pin 13 / dir. pin 14
1= Start / stop pin 13 / dir. pin 14
2= Start / brake pin 13 / dir. pin 14 (without ramp)
3= Start FW pin 13 / start BW pin 14 (continuous)
4= Start FW pin 13 / start BW pin 14 (impulse)
12. Current limit 0-100A / 1-100 (40)
0= Current setting with pin 18
13. Speed-2 input mode 0-100 (50)
0= stop input with rising edge (with ramp)
1= brake input with rising edge (without ramp)
10-100 = speed-2 preset value
14. I-trip reset and disable input (0)
0= I-trip reset only with disable input
1= I-trip reset with disable in and with speed in to 0
2 =I-trip reset with disable in and with dir. input
3 =I-trip reset with new start command or speed set to zero.
Disable input works as emerg. input, Releasing the disable input does not cause start, it requires a new start command
10-200 = Timer reset 1-20s. (0)
15. Over temp reset mode (0)
0= Only with disable input
1= With speed input change 0 to up and values 10-200 timer reset 1-20s.
16. I-trip and overcurrent indication (0)
0= I-trip indication to pin16
1= No I trip indication to pin 16 or 19
2= I-trip indication to pin 19
3= Pin 19 reserved only for I-trip indication
4= Overcurrent indication to pin 16
17. Pulse output for pin19 0-5 (0)
0= Not in use = pin 19 set with parameter 16)
1= 3pulse/round (possible only when param 2 is 2,3 or 4)
2= 1pulse/round
3= 1pulse/ 2round
4= 1pulse/ 3round
5= 1pulse/ 6round
6= I-motor to freq. output -40...0..50A <=> 10...50...100Hz
18. Brake res. threshold (=overvoltage) 15-65V / 15-65 (40)

MONITOR VALUES

1. Current 0-250A / 0-250
2. Braking current 0-250A / 0-250
3. Hall freq. 0-1000Hz / 0-1000
4. Operating voltage 0-75V / 0-750