

EM-346 BRUSHLESS DC-MOTOR DRIVER 12-35V 10A

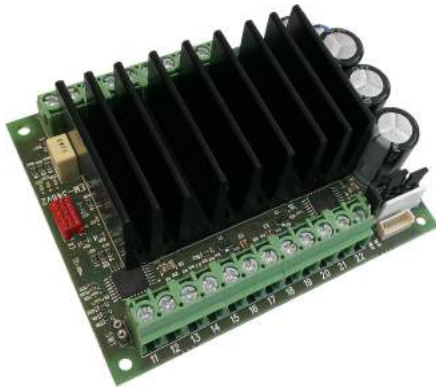

FEATURES

- Three phase output
- Speed and torque adjustment
- Open/closed loop modes
- Regenerative braking option
- True 4Q-power stage
- Braking resistor output
- Current limit and trip
- Symmetrical control option $\pm 5V$ or $\pm 10V$
- Fault and overcurrent outputs
- Good efficiency
- Low EMC emissions
- DIN-rail mountable
- Rpm-pulse output option

GENERAL

EM-346 is brushless DC-motor driver with hall sensor feedback. The unit has a mosfet power stage with good efficiency and it meets also today's EMC requirements. The driver can be used with 120° commutation. This driver has true 4Q power stage, and it makes possible to use regenerative braking. In this braking method the supply voltage rises, this voltage rising can be controlled with braking resistor. If uses battery supply then the braking energy can be leaded back to battery and braking resistor will not needed. The unit has the basic digital command inputs like direction, brake, start/stop, disable and there is analog inputs for speed and current control. One digitally presettable second speed (speed-2) is possible to activate with digital command input. EM-346 has two NPN outputs for fault and overcurrent indication use. Some input and output functions can be modified with parameters. Driver includes overvoltage, undervoltage and overtemperature protections. These fault situations are indicated with fault on-board LED. Overtemperature and current limit situations can be reset with reset input, reset-timer or by setting analog speed control to value to 0.

There are two control options for speed. Direct control (open loop) sets motor voltage in proportion to control voltage as with a standard DC-motor. Closed loop uses hall sensor feedback for speed control, this mode offers good speed regulation. Start and stop ramps work in both mode. Speed adjust range, closed loop rpm range and ramp can be set with parameter. Analog input are filtered so that there can also use PWM signal for control speed and current.

Setting can be done digitally with EM-236 interface unit or with Emen-Tool lite program installed in PC and EM-268 adapter cable. Parameters stored into nonvolatile memory of device. This interface unit can also be monitored the current and rpm of motor.

Device can be installed in DIN-rail base and some enclosure options are also available.

TECHNICAL DATA

Supply voltage 12-24V (11-35Vdc)
 Overvoltage shut down 40V
 Idle current typ. 30mA
 Max current 10A cont (Tamb. 40 °C)
 Max current peak 25A (max 2s)
 Max brake output current 10A
 Pwm frequency typ. 16kHz
 Overtemperature Temp shut down 90°C
 Current limit setting 0.1-25A (step 0.1 A)
 Current limit analog scale 0-5V = 0-25A
 Logic level of digital inputs
 "off" = 0-1V or open / "on" = 4-30V
 Input impedance of logic inputs 10k
 Response time of digital input 2ms
 Analog input range 0-5V up to 0-10V
 Input impedance of analog inputs 100k
 Input filter of analog input 100Hz
 Overcur. and fault outputs NPN max 50mA
 EMC measured for industrial and household env.
 PCB material flammability class UL94V-0
 Dimensions 89x73x32mm
 Weight 200g

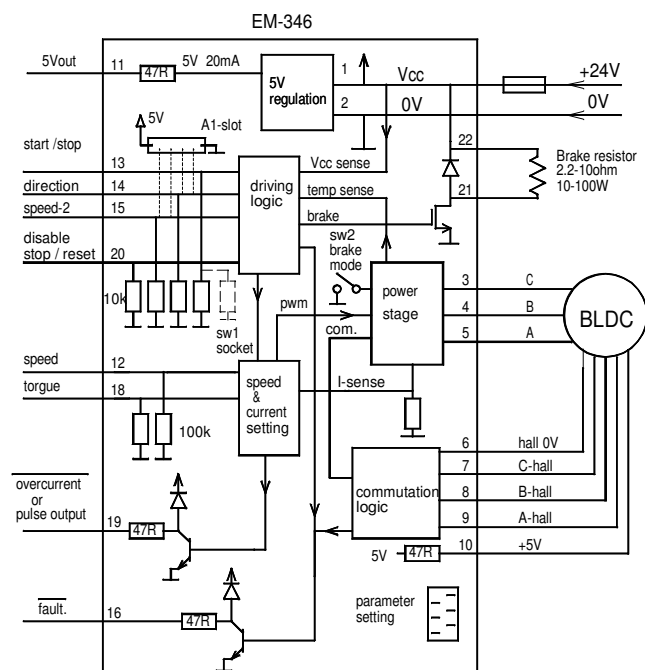

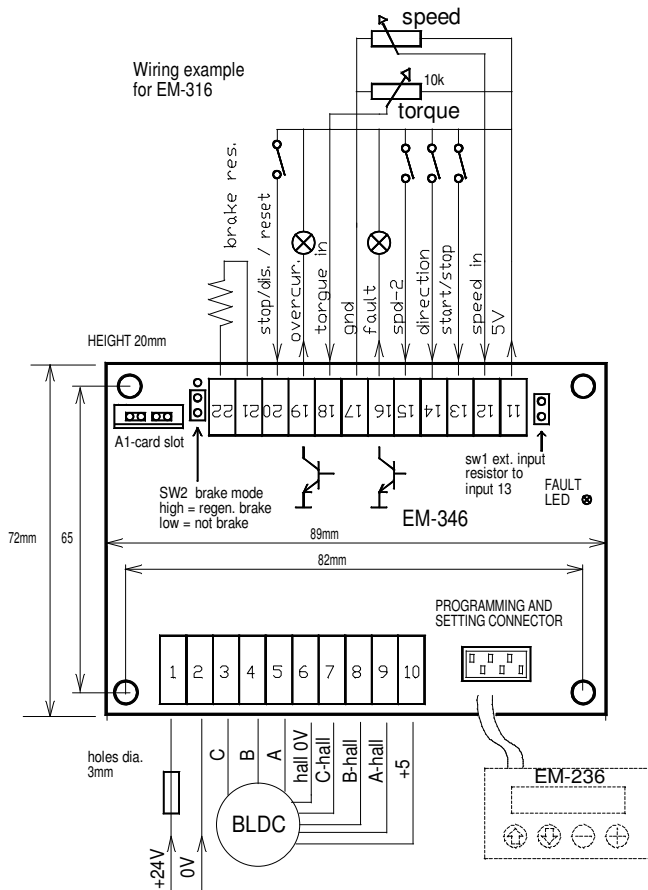

TAKE IN USE

Operating voltage 12-35Vdc ripple less than 20%
An external supply fuse is recommended (2-16A)

Be sharp when connect motor wires, because there is lot of combination. If motor takes much current or run roughly then change wiring.

Default settings are in brackets in parameter list.
This are good start-up values

In example picture beside there all input connected, but device work also with less wiring. So connect only needed functions.

Overcurrent and fault outputs are NPN type, and pull when activates, This could also connect to PNP input if uses 2.2k external pull up resistor

Speed adjusting input range can be set with parameter 6 and 7. see picture below

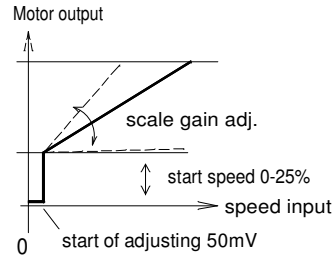

In some application load can be generated energy back to drive, when slowing down speed. Then there needed braking resistor, which absorbed extra energy. NOTICE that the parameter 18 has to be set about 10% higher than unloaded voltage of power supply. If uses battery supply, then braking resistor would not needed.

If needed symmetrical control $\pm 5V$ or $\pm 10V$ the, then can be added EM-A1 auxiliary card into A1 slot. Normally this slot has to be to jumpers pin 2 to 3 and pin 4 to 5

SETTABLE PARAMETERS (prog. 346 v1.0)

EM-346 parameters set with interface unit EM-236 or with Ementool-Lite and EM-268

1. mode: open loop =0 / closed loop=1 (0)
2. closed loop range 0-4 (3)
0=3000rpm
1=1500rpm
2=900rpm
3=500rpm
4=300rpm
3. start ramp 0-5s / 0-50 (1s)
4. stop ramp 0-5s / 0-50 (1s)
5. I-trip delay 1-255ms / 0-255 0=no trip (200ms)
6. scale start speed 0-25.5% / 0-255 (0)
7. scale gain 0-2.55 / 0-255 (200)
8. closed loop dynamic P-factor 1-200 (10)
9. closed loop dynamic I-factor 1-200 (10)
10. braking current limit 1-18A / 1-18 (18)
11. not in use this version 0-2
12. current limit 0-25A / 0.1-250 (40)
0= current setting with pin 18
13. speed-2 value 0-100% / 0-100 (50)
14. I-trip reset mode (0)
0= only with disable pin
1= with speed input change 0 to up
2= with direction input
10-200 = timer reset 1-20s. (0)
15. Over temp reset mode (0)
0= only with disable input
1= with speed input change 0 to up
2= 10-200 timer reset 1-20s.
16. I-trip indication (0)
0= I-trip indication to pin16
1= No I trip indication to pin 16 or 19
2= I-trip indication to pin 19
3= pin 19 reserved only for I-trip indication
17. pulse output for pin19 0-5 (0)
0= not in use = pin 19 set with parameter 16)
1= 3pulse/round (possible only when param 2 is 2,3 or 4)
2= 1pulse/round
3= 1pulse/ 2round
4= 1pulse/ 3round
5= 1pulse/ 6round
18. brake res. treshold (=overtoltage) 15-50V / 15-50 (36)

MONITOR VALUES

1. current 0-25A / 0-250
2. braking current 0-18A / 0-180
3. hall rpm 0-1000 / 0-1000Hz

CONTROL INPUTS

Speed input is a analog control input for speed setting.
Set signal can be between 0-5V and 0-10V
Speed scaling can be made with parameter 6 and 7.

Torque input is analog input for current limit setting.
0-5V signal to 0-25A current. (if parameter 12 is =0)
If parameter value is something else than zero, then current limit is then = parameter value + analog input value.

Analog inputs above can also control with PWM signal.
Recommended PWM frequency is over 400Hz.

Start/stop input must be set "high " (>4V) to start motor
If this in put is low or open, then the would not start.

Direction input is a digital input. It will change the rotation direction. It uses automatically stop/start ramps during change.

Speed-2 input is a digital input which. enables speed-2,
Speed presetted with parameter 13.

Stop/ disable input is a digital input, which disabled driver
Motor goes to freewheeling (all poles floating). This input can be set to work also as reset with parameter 14 and 15
This input has highest priority.

INDICATIONS.

Fault led:
Fast blinking = I-trip or overvoltage
Random blinking = current limit
Continuous = overtemp, disable input "on",

Fault output: (Pin-16 PNP open collector output)
Overtemperature, Overvoltage, Undervoltage.
This indicates also I-Trip if parameter 16 is set to = 0

Overcurrent output : (pin-19 PNP open collector out)
This output indicates when current limit is exceeded.
- if parameter 16 is set to =2 then it indicates also I-trip
- if parameter 16 is set to =3 then it indicates only I-trip