

EM-324 DC-MOTOR CONTROLLER 12-24V 4A

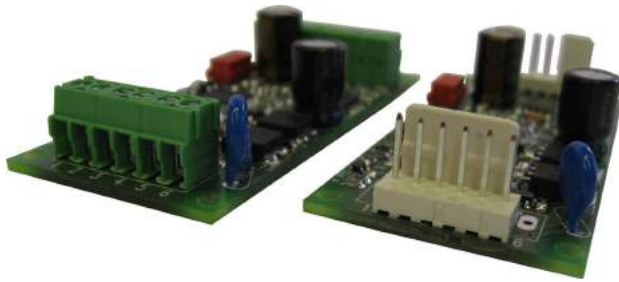

- small size
- high current output
- current limit
- zero current limit
- overvoltage brake
- speed setting
- flexible control inputs
- impulse / continuous mode
- rail base mountable
- digital parameter setting

EM-324 is a full bridge DC-motor starter. It is designed to work with DC-motor in applications where some special functions are needed. Starter has adjustable acceleration and deceleration ramps, which make possible the smooth starts and stops. Adjustable current limit protects motor against overcurrent and it can also be used as an end-stop. This device has also two settable speeds, which are useful in positioning applications. Control inputs FW and BW start the forward and backward run. STOP is for the motor shut-down but there are also available individual limit inputs for FW and BW directions. SPEED-2 input activates preset speed-2, but it can also be used as input for analog speed control signal 0-5V. FAULT terminal has at the same time input and output function, the pin is normally high, but is pulled down in overheat and conditionally also in current trip situation. If FAULT-line is pulled down externally it will cause a stop and prevent the new start. For example, it is possible to link fault pins of several units together and achieve a synchronous stop. There are two selectable control modes, continuous and impulse. In continuous mode the motor runs as long as the control is active. In impulse mode a short comand starts the motor, and only a new impulse will change the status. There is also few special settings start-kick and auto reverse. The card has selectable input logics. Inputs are divided in two groups, control and limit -inputs. Groups can be individually set for NPN or PNP logic. The parameters are set with EM-236 interface unit. Operation of the controller and some of its functional values can also be monitored with EM-236 interface unit.

TECHNICAL DATA (prog ver. 324 v1.0)

Supply voltage cont. max. 10-35V
 Overvoltage limit adjustable 15-40V (connect motor to free)
 Overvoltage dynamic brake 40V (shorting motor poles)
 Start up voltage 9V, shutdown voltage 8V
 Motor current cont. max. 4A, peak max. 7A ($T_a < 50^\circ\text{C}$)
 Current limit adjustable 0.1-5A (at start max 7A)
 Overheat limit 100 °C
 Start and stop ramp adjustable 0-5s
 PWM frequency 2kHz
 Speed input scale (speed-2) 0-5V = 0-100% pwm
 Input control logic: high =4-30V, low=0-1V
 Control input impedances typ. 47kohm
 Limit FW / BW input impeded. typ 10kohm
 Control input response time typ 5ms.
 Fault out. NPN open coll. max 30V / 50mA
 Fault in activates $U_{in} < 1\text{V}$ (NPN)
 Connectors 1mm screw or Molex 2.5mm pitch
 Dimensions 32x72x18mm
 Dimensions in DIN-rail base 35x80x38mm
 CE-tested for industrial environment (emc)
 Operating temp (T_a) -40...60 °C
 Weight 25g

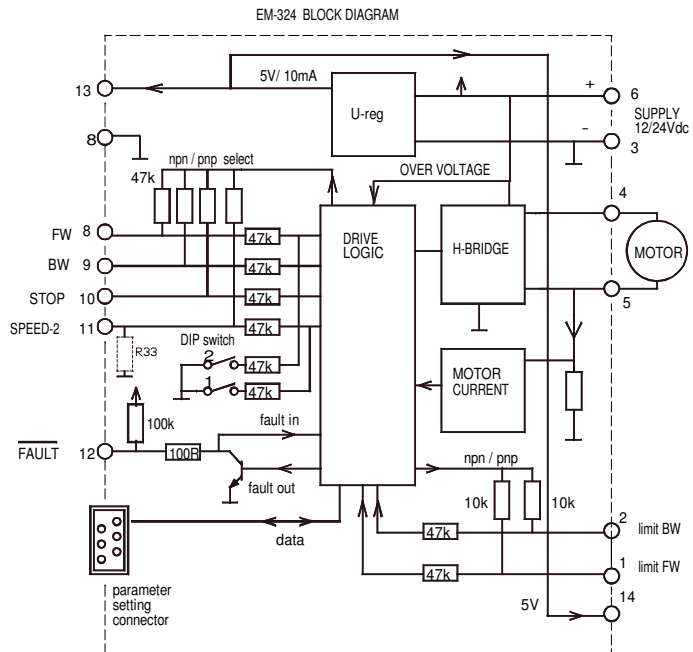

CONNECTIONS

Supply voltage must be filtered DC of 10-35V, and ripple should be less than 30% at full load.
CAUTION ! Wrong polarity can damage the unit.
CAUTION ! Unit doesn't have an internal fuse, so an external fuse should be added if fuse required.

MONITORABLE VALUES

- 1/5 Motor current 0-20A (0-200)
- 2/5 PWM-level-% 0-100% (0-100)
- 3/5 hour counter (max.65535h)
- 4/5 start counter (max.65535)
- 5/5 carry counter for start counter

FAULT-LED signal codes

- | | |
|---------------------|------------------------------|
| 1. power on | one blink |
| 2. current on limit | led is lit |
| 3. current trip | fast blinking... |
| 4. zero-cur trip | long blink- short pause... |
| 5. overvoltage | 4 x blink -pause... |
| 6. overheat | short blink- long pause... |
| 7. timeout | 3 x blink + long blink... |
| 8. fault input | 2 x short + 1x long blink... |

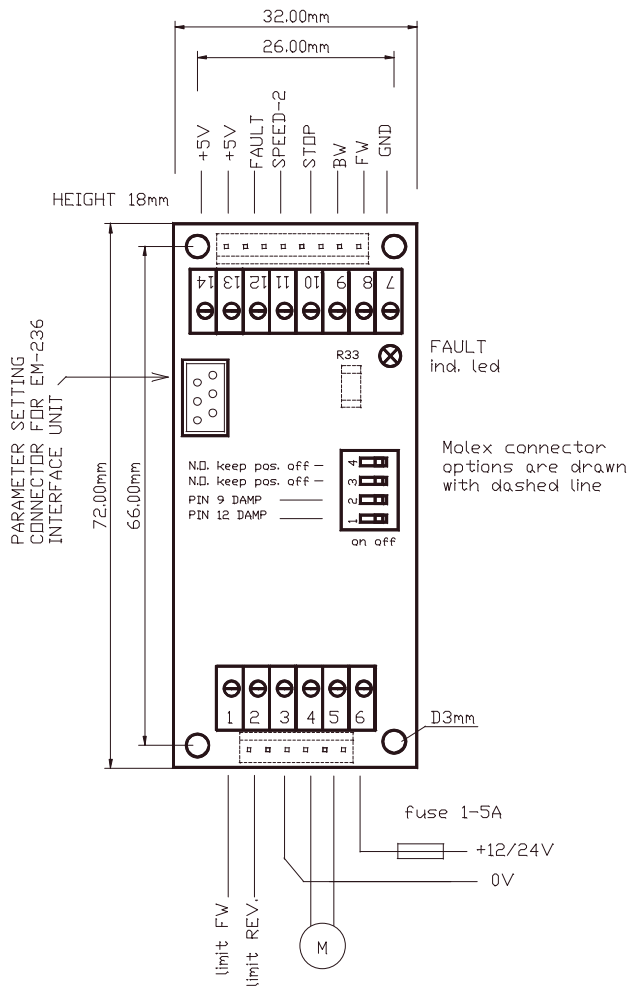

ADJUSTMENT AND SETTINGS (prog ver. EM-324 v1.0)

Adjusting and parameter setting of eg. current limit value, ramp times and speed-2 value is done with the EM-236 interface unit. With EM-236 the parameters and adjusted values can also be copied to multiple devices accurately and reliably.

SETTABLE PARAMETERS 18pcs. (defaults in brackets)

- 1- command mode: 0,1 and 2 (0)
 - 0= continuous FW / REV
 - 1= impulse commands FW / REV. with stop
 - 2=impulse commands FW / REV without stop
- 2- start condition combinations: 0-3 (1)
 - 0= start both direction after I-trip and Stop
 - 1= start only opposite direction after I-trip
 - 2= start only opposite direction after Stop
 - 3= start only opposite direction after I- and Stop
- 3- input logic combinations 0-3 PNP/NPN (0)
 - 0= command and limit inputs as PNP (positive)
 - 1= command inputs NPN, and limit inputs PNP
 - 2= command inputs PNP. and limit input NPN
 - 3= command and limit inputs NPN (negative)
- 4- running speed-1: 0-100% / 0-100 (100)
- 5- running speed-2: 0-100% / 0-100 (50)
 - Note: If selected to 0 or 1 "speed2-input" is used as analog 0-5V speed control input, and when 1 is selected FW direction is automatically "on" and FWD input works as direction change
- 6- current limit FW: 0.1-5A / 1-50 (30)
- 7- current limit REV: 0.1-5A / 1-50 (30)
- 8- Trip combinations: 0-3 (1)
 - 0= no I-trip, no zero-current-trip
 - 1= only I-trip
 - 2= only zero-current-trip
 - 3= both I-trip and zero-current-trip
- 9- I-trip delay: 0-255ms / 0-255 (20)
- 10- Fault output combinations: 0-3 (1)
 - 0= I-trip and zero current won't cause fault output signal
 - 1= only I-trip causes fault output signal
 - 2= only zero current causes fault output signal
 - 3= both I-trip and zero current causes fault output signal.
- 11- overvoltage limit: 15-40V / 15-40 (35)
 - Overvoltage can be caused by load driving the motor or when braking the speed down but supply can not accept the current back from driver. Exceeding the limit will cause the power stage set to free-wheel state. With a direct battery supply the brake current is charging the battery and the voltage will not normally rise. There is also 40V fixed dynamic brake point = motor pole shorted
- 12- load compensation: 0-255 / 0-255 (0)
 - Load compensation (Rxl) improves low speed and start torque, but too high compensation achieve unstable running. Run motor at low speed (30%) Increase compensation with small steps until motor start behaviour unstable, then decrease value about 10%
- 13- timeout: 0-255s. / 0-255 (0=not in use) (0)
- 14- Reset for start and hour-counter 0/1 (0)
 - selecting 1 and push SAVE => reset counters
- 15- start ramp: 0-5s / 0-500 (100)
- 16- stop ramp: 0-5s / 0-500 (100)
- 17- start-kick 0-200ms / 0-200 (0)
 - This gives full drive at start and I-lim is 7A
 - The start kick length is 0-200ms.
- 18- I-trip auto reversing 0-5s / 0-500 (0)
 - Change automatically run direction when I-trip occurs the reversing time will select with this parameter