

EM-291A BRUSHLESS DC-MOTOR DRIVER 12-35V 4A

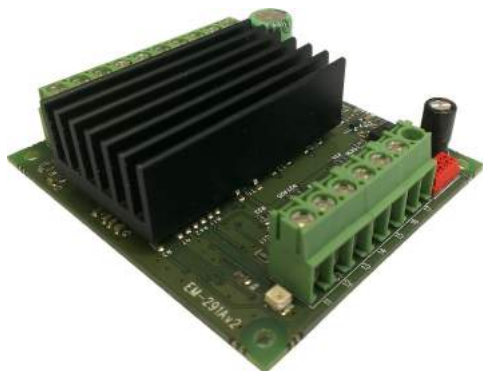

FEATURES

- Three phase output
- Speed adjustment
- Current limit and trip.
- Open/closed loop modes
- Settable Indication output
- Good efficiency
- Low EMC emissions
- DIN-rail mountable

GENERAL

EM-291A is brushless DC-motor driver for motors with hall sensor feedback. The unit has a mosfet power stage with good efficiency and it meets also today's EMC requirements. The unit has the basic digital command inputs like direction, start/stop, and analog input for speed control. Device has one NPN output for fault and overcurrent indication use. Indication output functions can be defined with parameter. The fault situations are also indicated with on-board LED.

There are two control options for speed. Direct control (open loop) sets motor voltage in proportion to control voltage as with a standard DC-motor. Closed loop mode uses hall sensor feedback for speed control. This mode offers good speed regulation. Start and stop ramps are working in both mode. Speed adjust range, closed loop rpm range and ramps can be set with parameters. Analog input is filtered, so that also PWM signal of PLC can be used to control speed.

Parameter setting can be done digitally with EM-236 interface unit or with Emen-Tool lite PC-program and EM-268 adapter. There is also an option to use iPhone with Ementool-APP and EM-326 adapter. The Parameters setting are stored into driver's nonvolatile memory. The parameter interfaces can be also used for motor current monitoring.

Driver card can be installed in DIN-rail base and some enclosure options are also available.

TECHNICAL DATA

Supply voltage 12-24V (11-35Vdc)
 Idle current typ. 30mA
 Max current 4A cont. (Tamb. 40 °C)
 Max current peak 6A (max 5s)
 PWM frequency typ. 16kHz
 Current limit setting 0.1-6A (step 0.1 A)
 Logic level of digital inputs
 0-1V or open = "off" / 4-30V = "on"
 Logic level of disable input
 0-1V or open = disabled / 4-30V = on duty
 Input impedance of logic inputs 10k
 Response time of digital inputs 2ms
 Analog input range 0-5V or 0-10V
 Input impedance of analog input 47k
 Speed input low pass filter fc. = 40Hz
 Speed input pwm freq. recom. > 300Hz
 NPN Indication output impedance 100ohm
 EMC measured for industrial and household env.
 PCB material flammability class UL94V-0
 Screw connectors, max 2.5mm² cable
 Dimensions 72x65x20mm
 Din-rail option EM-KP72-65
 Metal-enclosure option EM-T17
 Weight 78g

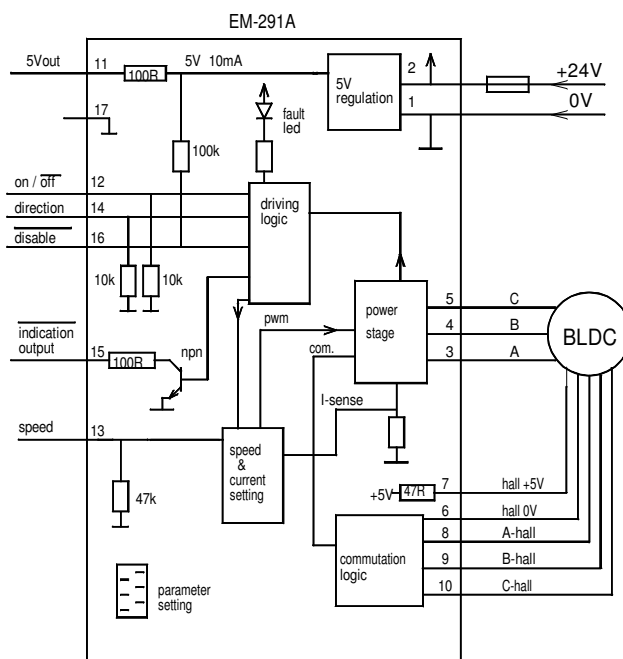

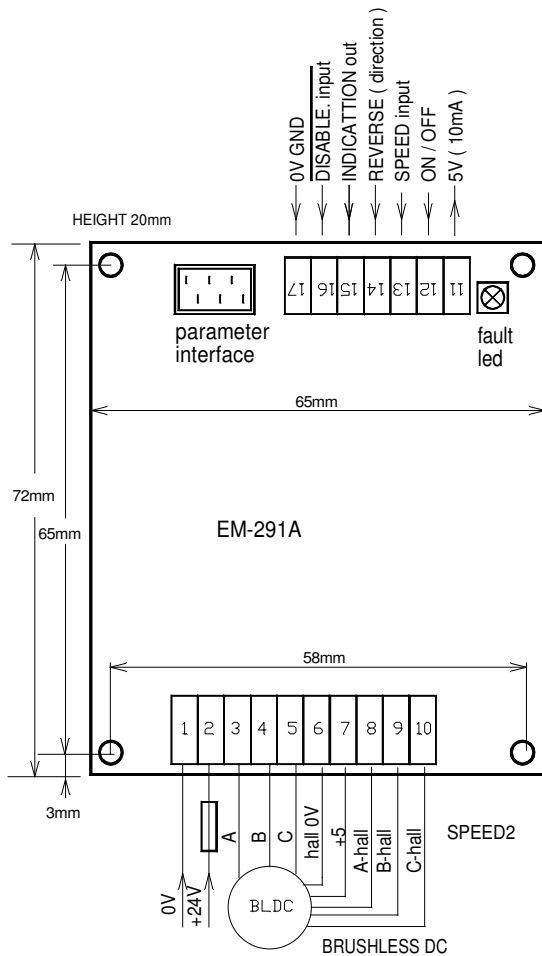

EM-291A WIRING and INTRODUCTION

Supply: filtered 12-35VDC with ripple < 20% with full load.
CAUTION ! reverse polarity can damage the unit
CAUTION ! use an external fuse

Switch off power before connecting motor and power supply to EM-291A unit. Prepare the control circuit.
 Switch on the unit, connect the interface and set current limit and ramp time according to application.
 If motor will not start and takes a lot of current or run unsmooth, check the wiring of the motor and hall-sensors.

In open loop mode motor rpm will drop when loaded, The load compensation parameter can be used to reduce speed dropping in open loop mode.
 In Closed loop mode the feedback control try to keep speed a constant (in relation to control voltage) until the current limit is exceeded.

ON/OFF and REV.. inputs can be used with switches or NPN outputs of a logic. Voltage signal greater than 4V is logic "1", maximum input voltage is 30V. ON/OFF input will start up the motor to forward direction. REVERSE input will start up the motor to reverse direction. When motor is already running forward direction, a reverse command will change rotation of direction.
 The disable input releases power stage, so motor will run freely. When disable is removed the motor will start with ramp. Notice, the disable input works with negative logic.

On board fault led indicates overcurrent or current trip.

PARAMETERS SETTINGS (prog. 291A v1.2)

EM-291A parameters set with interface unit EM-236 or with Ementool-Lite and EM-268 or with Ementool-APP and EM-326 (default values in brackets)

- operating mode
0 = Open loop / 1 = Closed loop (0)
- rpm range in closed loop 1000-18000rpm / 1-18 (6)
- closed loop dynamic 1-5 (3)
higher value means slower dynamic.
- Input scale 0 =0-10V / 1= 0-5V
- load compensation (only open loop use) 0-50 (0)
- start ramp 0-8 / 0, 0.1, 0.2, 0.3, 0.4, 0.5, 0.7, 1.0, 1.5s (4)
- stop ramp 0-8 / 0, 0.1, 0.2, 0.3, 0.4, 0.5, 0.7, 1.0, 1.5s (4)
- current limit 0-6A / 0-60 (15)
- current trip delay 0= trip disabled
1-200 = 1-200ms delay(40)
- indication output function (1)
0 =not in use, 1=current trip, 2= current limit, 3= motor stopped

PARAMETERS DEFINITION

- Open loop or closed loop selection
- Closed loop RPM range can be defined with this parameter
1000 means that motor speed range is 0-1000rpm
- Closed loop dynamic set the closed loop control response
higher value means slower response
- Two selectable basic speed input scale ranges.
- Load compensation can be needed in open loop use. It gives additive torque at low rpm. The compensation value depends on motor. Right value can be found next way: Drive motor at low speed in open loop mode. Increase the compensation value for example 5 step at once and try to load motor. You can feel that the motor torque is increased. Notice too high compensation value will cause nervous behaviour of the motor. Keep the compensation value 0 at closed loop mode.
- & 7 acceleration and deceleration ramps. these parameters for smoothening the start stop situations. The start ramp also decreases start current spikes.
- Current limit parameter defines maximum value for current. Driver limits or trips if set value is exceeded. The current is in ratio for motor torque.
- This parameter sets reaction time for current trip.
Value 0 disabled current trip action, then current only will be limited to the value set with param 8. The values 1-200ms set how long time current limit has to been exceeded, until driver shut down motor.
- Disabling or selecting the indication output function.

MONITOR VALUES

- trip status
0= no trip, 1= tripped for FW dir, 2=tripped for REV. dir.
- Speed input signal value
- Motor current 0-30 = 0-3.0A

OTHER.

An iPhone access code can be set when EmenTool-APP control is used. This code can be reset with simultaneous REV. and ON/OFF commands at the same time when power switch on.