

DC-MOTOR CONTROLLER EM-282C-48V 24-48Vdc 80A

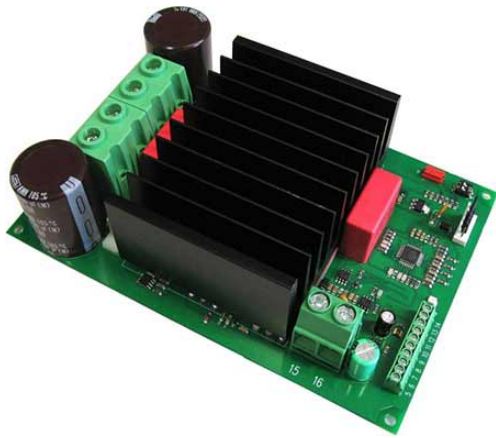

FEATURES

- high current output
- brake load output
- suitable for 48V battery supply
- current limit
- current limit for brake also
- zero-current limit
- speed setting/adjustment
- flexible control inputs
- impulse / continuous mode
- rail base mountable
- digital parameter setting
 - + 2/16kHz pwm freq. options
 - + freewheel options
 - + autoreverse option
 - + running indication options
 - + expanded input logic options
 - + thermal cont. Fan-output (pcb v.3)

EM-282 is a full bridge DC-motor starter. It is designed to work with DC-motor (permanent magnet and brushed) in applications where a variety of special functions and settings are needed. Starter has an adjustable acceleration and deceleration ramps enabling the smooth starts and stops. Adjustable current limit protects motor against overcurrent. Current limitation for braking is also available (regeneration). EM-282 has two selectable and settable speeds. This feature can be useful eg. in positioning applications. The FW and BW -inputs control the forward and backward run. STOP input is to stop the motor but there are also available individual limit inputs for FW and BW direction end stops that will cause a motor shut-down. SPEED-2 input activates the presettable speed-2, but it can also be set for use as an analog speed control input (0-5V signal). FAULT terminal operates same time as an input and output. Fault line is internally pulled high (100kohm to Vsupply), but will be pulled down in overheat or conditionally also in current trip situation. If FAULT-line is pulled down externally it will cause a stop and disable a new start. For example it is possible to link FAULT pins of several units together and achieve this way a synchronous stop.

Driving can be done with two selectable control modes, continuous and impulse. In continuous mode the motor runs as long as the command is on. In impulse mode a short command starts the motor, and only a new impulse will change the status. Inputs are divided in to two groups, command and limit -inputs. These groups can be individually set to work with NPN (connect to zero control) or PNP (positive voltage control) -logic. The parameters are set digitally with a hand held EM-236 interface unit. With this unit the same settings (adjustments) can also be easily copied to an other or to multiple devices. Operation of the controller and some of its functional values can also be monitored with EM-236 interface unit.

TECHNICAL DATA (prog. EM-282-48V prog v1.4 and pcb v.3 or later)

Supply voltage nom. 24-48Vdc (abs. limits 20-60V)
 Shutdown voltage 20V
 Overvoltage limit adjustable 20-65V
 Idle current typ 20mA
 Motor current max. continuous 80A (at 25°C amb. temp)
 70A (at 50° amb temp) and peak 160A (5s)
 Motor currents are about 20% lower if pwm frequency is 16kHz
 Braking load current (pin 16) max cont 30A peak 100A
 Current limit adjustable 1-200A
 NOTICE current limit is 20% boosted during start ramp
 Over temp. limit 100°C
 Start and stop ramp adjustable 0-5s
 PWM frequency 2kHz / 16kHz
 Speed input scale (speed-2) 0-4.5V = 0-100% pwm
 I-lim input scale 0-5V = 0-200A
 Input control logic: high =4-30V, low=0-1V
 Control input impedances typ. 10kohm
 Control input response time typ 5ms.
 Fault out. NPN open coll. max 42V / 0.5A
 Fault in. activates Uin < 1V (NPN with 100k pull up)
 Fan-output switch on 55°C, off 50°C (only pcb v.3 of later)
 Fan-output NPN max 40V 100mA
 12V Fan (+) max 100mA
 Motor and supply connectors 16mm²
 Control connectors 1mm²
 Dimensions 180x122x60mm
 CE-tested for industrial environment (EMC)
 Operating ambient temp (Ta) -40...60°C
 Weight 750g

EM-282 BLOCK DIAGRAM (board ver. v.3)

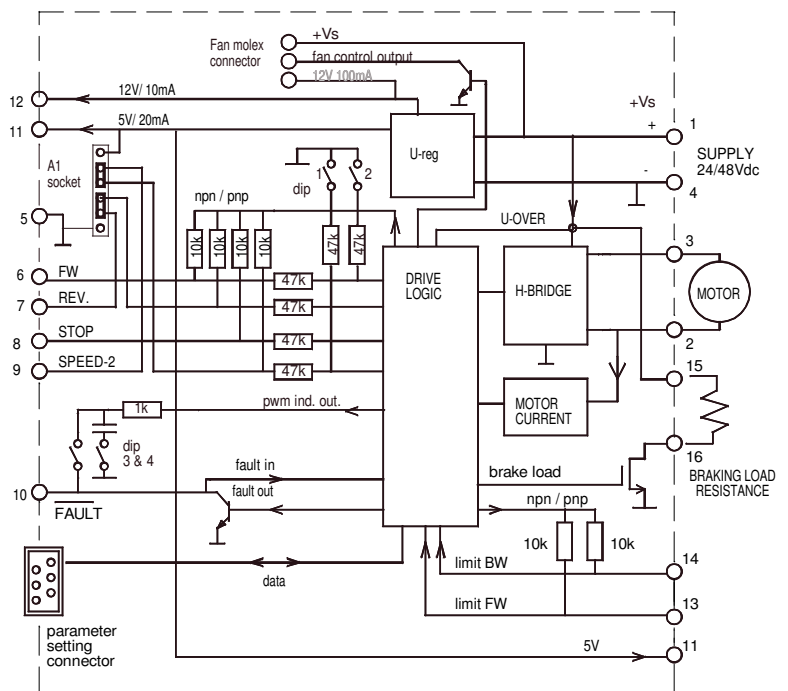

CONNECTIONS

Supply voltage must be filtered DC of 24-60V, and ripple should be less than 20% at full load.
CAUTION ! Wrong polarity can damage the unit.
CAUTION ! Unit doesn't have an internal fuse.
 So if required, an external fuse should be added.
NOTICE ! thermal controlled FAN-out only in PCB ver3 or more

ADJUSTMENT AND SETTINGS (prog. EM-282C v.1.3)
 Settings can be done with 3 interface device options.

1. EM-236 interface unit
2. EM-328 series interface units with EmenTool Lite PC-software
3. EM-326 interface unit with EmenTool App smartphone application. If using App you can set device-specific access code, which protects device against unauthorized smartphone connections.
 The access code can be reset with simultaneous FW and BW comand, when power switch on.

SETTABLE PARAMETERS (EM-282C v1.4 defaults in brackets)

- 1 command mode: continuous = 0, impulse = 1 (0)
- 2 start condition combinations: 0-3 (1)
 0= start both direction after I-trip and Stop
 1= start only opposite direction after I-trip
 2= start only opposite direction after Stop
 3= start only opposite direction after I- and Stop
- 3 input logic combinations 0-7 PNP/NPN (0)
 PNP control with positive signal and input has pull down res.
 NPN control with negative signal and input has pull up res.
 N.C. = input resistor as above, but control signal is inverted
 0= cont. PNP, limits PNP 4=cont. PNP, limits PNP N.C.
 1= cont. NPN, limits PNP 5=cont. NPN, limits PNP N.C.
 2= cont. PNP, limits NPN N.C. 6=cont. PNP, limits NPN
 3= cont. NPN, limits NPN N.C. 7=cont. NPN, limits NPN
- 4 running speed-1: 0-100% / 0-100 (100)
- 5 running speed-2: 0-100% / 0-100 (50)
 Note: If selected to 0 "speed-2 input" is used as analog 0-5V speed control input.
 Note2: If selected to 1 "speed-2 input" is used as analog 0-5V speed control input, and run start automatically and REV. input changes direction
- 6 current limit : FW 0-200A / 0-200 (30)
- 7 current limit : BW 0-200A / 0-200 (30)
 NOTICE! if both 6 & 7 is set = 0, then I-lim input is active
- 8 Trip combinations: 0-3 (1)
 0= no I-trip, no zero-current-trip
 1= only I-trip
 2= only zero-current-trip
 3= both I-trip and zero-current-trip
- 9 I-trip delay: 0-255ms / 0-255 (20)
- 10 Fault output combinations: 0-5 (1)
 0= I-trip and zero current won't cause fault output signal
 1= only I-trip causes fault output signal
 2= only zero current causes fault output signal
 3= both I-trip and zero current causes fault output signal.
 4 = overcurrent indication
 5 = "run" indication = pull down when motor run

FAULT-LED signal codes

- | | |
|---------------------|------------------------------|
| 1. power on | one blink |
| 2. current on limit | led is lit |
| 3. current trip | fast blinking... |
| 4. zero-cur trip | long blink- short pause... |
| 5. over voltage | 4 x blink -pause... |
| 6. over heat | short blink- long pause... |
| 7. time-out | 3 x blink + long blink... |
| 8. fault input | 2 x short + 1x long blink... |

MONITORABLE VALUES (EM-236 / EmenTool)

- 1 Motor current 0-200A (0-200)
- 2 PWM-level-% 0-100% (0-100)
- 3 hour counter (max.65535h)
- 4 start counter (max.65535)
- 5 carry counter for start counter
- 6 Braking current 0-200A (0-200)

- 11 overvoltage limit: 20-65V / 20-65 (60)
 Overvoltage can be caused by load driving the motor or when braking the speed down but supply can not accept the current back from driver. Exceeding the limit will cause first the brake load switch on and if voltage still rise 10% as limit value the power stage set to free-wheel state.
 With a direct battery supply the brake current is charging the battery and the voltage will not normally rise.
- 12 load compensation: 0-255 / 0-255 (0)
 Load compensation (Rxl) improves low speed and start torque, but too high compensation achieve unstable running. Run motor at low speed (30%) Increase compensation with small steps until motor start behaviour unstable, then decrease value about 10%
- 13 timeout: 0-255s. / 0-255 (0=not in use) (0)
- 14 reset for start and hour-counter 0/1 (0)
 selecting 1 and push save = reset counters
- 15 start ramp: 0.2-5s / 0-500 (100)
- 16 stop ramp: 0.2-5s / 0-500 (100)
- 17 start kick 0-200ms / 0-200 (0)
 gives short 0-200ms full drive pulse for start
- 18- I-trip auto reversing 0-5s / 0-500 (0)
 Change automatically run direction when I-trip occurs the revesing time will select with this parameter
- 19- Freewheel options 0-5 (0)
 0= freewheeling when overvoltage
 1= freewheeling when overv. or stopped
 2= freewheeling when overv. or during stop ramp
 3= freewheeling when overv. or when stopped or during stop ramp
 4= freewheeling when stopped
 5= freewheeling disabled
- 20- Pwm frequency 1=2kHz / 2=16kHz
- 21- Current limit in braking 5-200A / 5-200 (50)
- 22- Pin-16 (brake load) options 0-2 (0)
 0= regen. braking = switch on when overvoltage exceed
 1= running indication = switch on pin-16 when motor run
 2= as above but also stop input switch on pin-16

