

EM-243C DC-MOTOR CONTROLLER 12-48V 50A

FEATURES (notice Prog. and PCB versions)

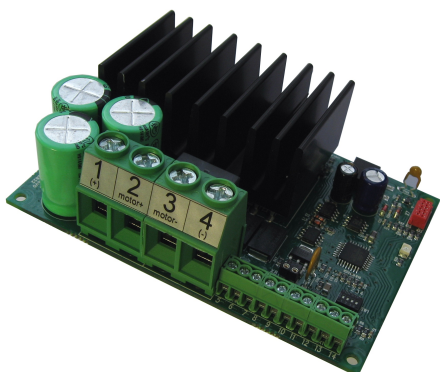

- small size
- high current output
- current limit
- zero current limit
- speed setting
- flexible control inputs
- impulse / continuous mode
- rail base mountable
- digital parameter setting
- C ver. card compatible with A version card
- C firmware can be loaded A-ver. card
- C ver. new features
 - + freewheel options parameter (param 19)
 - + 2 or 16kHz pwm freq.select (param. 20)
 - + current limit analog input (param 6&7)
 - + speed+dir operating mode (param. 5)
 - + Fan and Brake available in board 243C v.2
 - + Extend operating voltage in board 243C v.2
 - + prog. -C v1.5 speed input range adjust
 - + prog -C v1.7 bus option / pause input

EM-243C is a full bridge DC-motor starter. It is designed to work with DC-motor in applications where some special functions are needed. Starter has adjustable acceleration and deceleration ramps, which make possible the smooth starts and stops. Adjustable current limit protects motor against overcurrent and it can also be used as an end-stop. This device has also two settable speeds, which are usefull in positioning applications. Control inputs FW and BW start the forward and backward run. STOP is for the motor shut-down but there are also available individual limit inputs for FW and BW directions. SPEED-2 input activates preset speed-2, but it can also be used as input for analog speed control signal 0-5V. FAULT terminal has at the same time input and output function, the pin is normally high, but is pulled down in overheat and conditionally also in current trip situation. If FAULT-line is pulled down externally it will cause a stop and prevent the new start. For example, it is possible to link fault pins of several units together and achieve a synchronous stop. There are 2 selectable control modes, continuous and impulse. In continuous mode the motor runs as long as the control is active. In impulse mode a short comand starts the motor, and only a new impulse will change the status. The card has selectable input logics. Inputs are divided in two groups, control and limit -inputs. Groups can be individually set for NPN or PNP logic. The parameters are set with EM-236 interface unit. Operation of the controller and some of its functional values can also be monitored with EM-236 interface unit. In C-version program is possible to select 16kHz pwm frequency (= silent) but notice that current output capability is lower with 16kHz.

TECHNICAL DATA

Supply voltage nominal 12-48V, limits 10-58V
 Start up voltage 9V, shutdown voltage 8V
 Idle current typ 15mA
 Motor current max. with 2kHz pwm
 100% pwm 50A , 20-99pwm% 35A and peak 100A (5s)
 Motor current max. with 16kHz pwm
 100% pwm 40A , 20-99pwm% 20A and peak 60A (5s)
 Current limit adjustable 1-100A
 NOTICE ! during start ramp the current limit is 50% boosted
 Overheat limit 100°C
 Start and stop ramp adjustable 0-5s
 PWM frequency 2kHz or 16kHz
 Speed input range (pin 9) 0-1...5 or 0- 2...10V= 0-100% pwm
 this range can be adjust with parameter 4
 I-limit input scale (stop) 0-4V = 0-100A
 Input control logic: high =4-30V, low=0-1V
 Control input impedances typ. 10kohm
 Control input response time typ 5ms.
 Fault out. NPN open coll. max. 40V / 1A
 Fault in activates Uin < 1V (NPN)
 Fan-output switch on 55°C, off 50°C (only pcb Cv.2 of later)
 Fan-output NPN max. 40V 2A
 Break load output Max. 60V 5A
 Vout lim output max 25V 15mA
 Motor and supply connectors 2.5mm
 Control connectors 1mm
 Dimensions 107x73x40mm
 Dimensions in DIN-rail base 110x80x55mm
 CE-tested for industrial environment (EMC)
 Operating ambient temp (Ta) -40...60°C
 Weight 190g

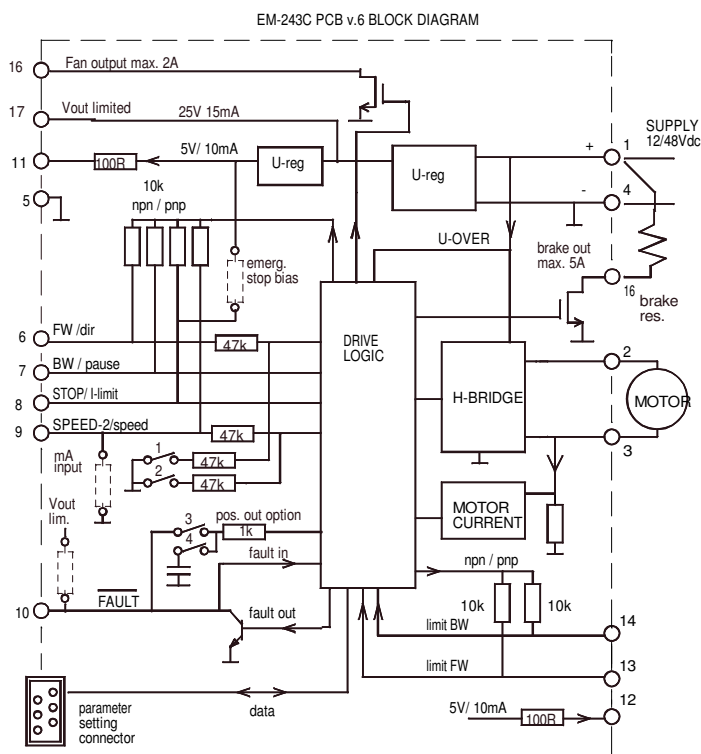

CONNECTIONS

Supply voltage recommendation is 12-48VDC and ripple should be less than 30% at full load. Supply voltage limit is 58Vdc
CAUTION ! Wrong polarity can damage the unit.
CAUTION ! Unit doesn't have an internal fuse, so an external fuse should be added if fuse required.

MONITORABLE VALUES

- 1/5 Motor current 0-100A (0-100)
- 2/5 PWM-level-% 0-100% (0-100)
- 3/5 hour counter (max.65535h)
- 4/5 start counter (max.65535)
- 5/5 carry counter for start counter

FAULT-LED signal codes

- 1. power on one blink
- 2. current on limit led is lit
- 3. current trip fast blinking...
- 4. zero-cur trip long blink- short pause...
- 5. overvoltage 4 x blink -pause...
- 6. overheat short blink- long pause...
- 7. timeout 3 x blink + long blink...
- 8. fault input 2 x short + 1x long blink...

ADJUSTMENT AND SETTINGS (prog. EM-243C v.1.7)

Settings can be done with 3 interface device options.

- 1. EM-236 interface unit
 - 2. EM-268 or 328 interface units with EmenTool Lite PC-software
 - 3. EM-326 interface unit with EmenTool App smartphone application.
- If using App you can set device-specific access code, which protects device against unauthorized smartphone connections. The access code can be reset with simultaneous FW and BW comand, when power switch on.

DIP SWITCHES

- Dip-1 input range (pin6) 0-5V=off / 0-10V=on (in analog speed modes)
- Dip-2 input range (pin9) 0-5V=off / 0-10V=on (in analog speed modes)
- Dip-3 position output option, keep OFF
- Dip-4 position output option, keep OFF

Limit inputs FW / BW

These inputs stop motor without ramp with dynamic brake
 But in control mode "2-speed" dynamic brake is enabled only when speed-2 is activated.
 If motor has stopped with limit switch the dynamic brake is at least 1s. active, also in case when freewheel is selected.

FAULT in/out

This NPN input pull down when fault. Combination can be selected with parameter 10.
 If this input is pulled down with externally, then it would disabled motor as long as pulled down.

SPEED-2 input

This input activates speed-2 when 2-speed mode is selected
 In analog speed modes this input work as speed set input

SERIAL PORT (red micromatch connector)

This is normally for parameter settings and monitoring with Ementool program or EM-interface units.
 But there is also availability for open protol control (Modbus)
 This option has own instruction guide.

SETTABLE PARAMETERS

prog. 243C v1.7 (defaults in brackets)

- 1 command mode: (0)
 continuous = 0,
 impulse = 1 direction change with stop
 impulse 2 = 2 dir. change without stop
- 2 start condition combinations: 0-3 (1)
 0= start both direction after I-trip and Stop
 1= start only opposite direction after I-trip
 2= start only opposite direction after Stop
 3= start only opposite direction after I- and Stop
- 3 input logic combinations 0-7 PNP/NPN (0)
 PNP control with positive signal and input has pull down res.
 NPN control with negative signal and input has pull up res.
 N.C. = input resistor as above, but control signal logic is inverted
- 0= cont. PNP, limits PNP 4=cont. PNP, limits PNP N.C.
 1= cont. NPN, limits PNP 5=cont. NPN, limits PNP N.C.
 2= cont. PNP, limits NPN N.C. 6=cont. PNP, limits NPN
 3= cont. NPN, limits NPN N.C. 7=cont. NPN, limits NPN
- 4 running speed-1: 0-100% / 0-100 (100)
 If analog speed input mode is select with parameter 5,
 then parameter 4 work analog input range adjust
- 5 control mode / running speed-2 preset 0-100% / 0-100 (50)
 0= Analog speed mode -1
 "speed 2-input" is used as analog 0-5V speed control input.
 1= Analog speed mode -2
 as above but FW direction is automatically "on" and
 FW input works as direction change input.
 BW input works as pause input
 2-100 = 2-speed mode (two digitally settable speed)
 speed-1 preset with param. 4 and speed-2 with param. 5)
- **6 current limit FW: 1-100A / 1-100 (10)
 **7 current limit REV: 1-100A / 1-100 (10)
 NOTICE ! If both 6 & 7 is set = 0, then I-limit input is enabled,
 and works as current limit adjust input.
- 8 Trip combinations: 0-3 (1)
 0= no I-trip, no zero-current-trip
 1= only I-trip
 2= only zero-current-trip
 3= both I-trip and zero-current-trip
- 9 I-trip delay: 0-255ms / 0-255 (20)
- 10 Fault output combinations: 0-3 (1)
 0= I-trip and zero current won't cause fault output signal
 1= only I-trip causes fault output signal
 2= only zero current causes fault output signal
 3= both I-trip and zero current causes fault output signal.
 4= overcurrent indication = pull down
 5= "run" indication = pull down when motor run
- 11 overvoltage limit: 15-60V / 15-60 (55)
 Overvoltage can be caused by load driving the motor or
 when braking the speed down but supply can not accept
 the current back from driver. Exceeding the limit will cause
 the power stage set to free-wheel state.
 With a direct battery supply the brake current is charging the
 battery and the voltage will not normally rise.
- 12 load compensation: 0-255 / 0-255 (0)
 Load compensation (Rxl) improves low speed and start
 torque, but too high compensation achieve unstable running.
 Run motor at low speed (30%) Increase compensation
 with small steps until motor start behaviour unstable,
 then decrease value about 10%
- 13 timeout: 0-255s. / 0-255 (0=not in use) (0)
- 14 reset for start and hour-counter 0/1 (0)
 selecting 1 and push save = reset counters
- 15 start ramp: 0-5s / 0-500 (100)
- 16 stop ramp: 0-5s / 0-500 (100)
- 17 start kick 0-200ms / 0-200 (0)
 gives short 0-200ms full drive pulse for start
- 18 I-trip auto reversing 0-5s / 0-500 (0)
 Change automatically run direction when I-trip occurs
 the reversing time will select with this parameter
- 19- Freewheel options 0-5 (0)
 0= freewheeling when overvoltage
 1= freewheeling when overv. or stopped
 2= freewheeling when overv. or during stop ramp
 3= freewheeling when overv. or when stopped or during stop ramp
- 20- Pwm frequency 1=2kHz / 2=16kHz (1)
- 21- Pin-16 (brake load) options 0-2 (0)
 0= regen. braking = switch on when overvoltage exceed
 1= running indication = switch on pin-16 when motor run
 2= as above but also stop input switch on pin-16
- 22 Serial line configuration, speed, parity, and number of stop bits (1)
 1 =9600bps 8N1 5 =19200bps 8N1
 2 =9600bps 8N2 6 =19200bps 8N2
 3 =9600bps 8E1 7 =19200bps 8E1
 4 =9600bps 8O1 8 =19200bps 8O1
- 23 Modbus address 1-247 (1)

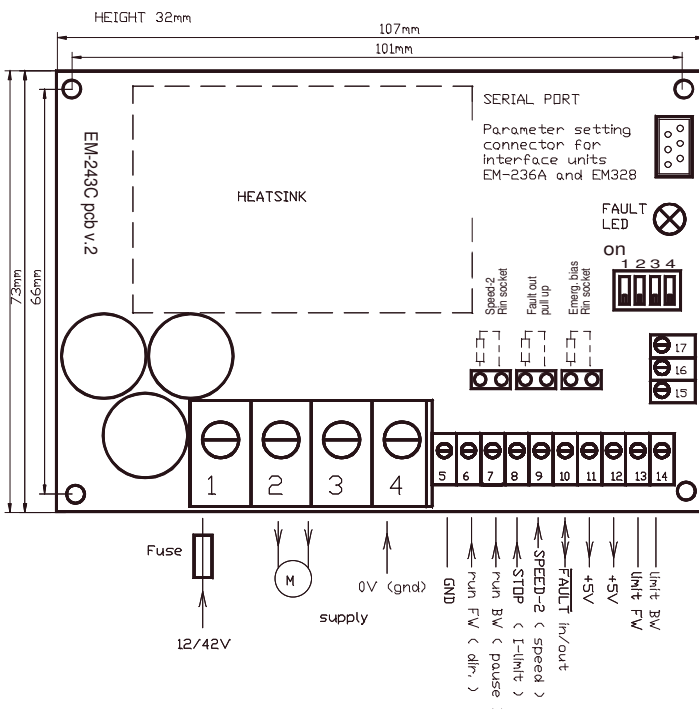

Vout 24V
 brake load out
 Fan output

- Optional resistor :
- 1. Speed-2 input 250ohm resistor if want to use 0-20mA speed set signal
 - 2. Fault output 2.2kohm res for pull up if want to connect for PNP input of PLC
 - 3. Emerg. bias resistor for stop input for stop input line monitoring in safety switch installation (need special software)

The special input functions below will be activate with parameters. In drawing these inputs are in brackets.

- *Analog speed mode-1, pin9=speed set.
- *Analog speed mode-2 pin9=speed set, 6=direction, 7=pause

**Analog I-lim input is activated with set param. 6&7= 0