

DCmind: BRUSHLESS MOTORS

Motors 34 to 192 W nominal output power range SMi21

- > Servomotor for position, speed and torque control applications
- > Very high power density
- > Built-in electronics with 6 inputs (2 of which are analog) and 4 outputs
- > Built-in 4096-pulse encoder
- > With application programs already debugged and saved in the motor
- > Expert programs can be used to adapt to the requirements of difficult applications
- > Parameters set on the PC via USB connection
- > Integrated bootloader for embedding special customer firmware



Parts number

	34 to 94 W			40 to 145 W			82 to 192 W		
Type	80140 SMi21			80180 SMi21			80280 SMi21		
Part numbers									
IP65 option	80140043			80180044			80280001		
Holding torque brake 0.5 Nm option	80140044			80180045			80280002		
Nominal operating range (V _{DC})	12 - 48			12 - 48			12 - 48		
Min. max. operating range (V _{DC})	9 - 56			9 - 56			9 - 56		
No-load characteristics	12 V _{DC}	24 V _{DC}	48 V _{DC}	12 V _{DC}	24 V _{DC}	48 V _{DC}	12 V _{DC}	24 V _{DC}	48 V _{DC}
Speed of rotation (rpm)	2400	4000	4000	1700	3500	4000	1500	3050	4000
Absorbed current (A)	0.3	0.3	0.2	0.3	0.33	0.2	0.38	0.44	0.35
Nominal characteristics	12 V _{DC}	24 V _{DC}	48 V _{DC}	12 V _{DC}	24 V _{DC}	48 V _{DC}	12 V _{DC}	24 V _{DC}	48 V _{DC}
Speed (rpm)	1460	3900	4000	1100	2900	4000	1100	2863	4000
Torque (mNm)	225	225	225	350	350	350	685	565	460
Absorbed current (A)	5.2	5.2	2.6	5.65	5.40	3.65	10	8	5
Output power (W)	34	92	94	40	105	145	82	170	192
Maximal characteristics	12 V _{DC}	24 V _{DC}	48 V _{DC}	12 V _{DC}	24 V _{DC}	48 V _{DC}	12 V _{DC}	24 V _{DC}	48 V _{DC}
Speed of rotation (rpm)	1100	3000	4000	1000	2400	4000	740	2250	4000
Torque (mNm)	300	400	440	400	600	750	1000	1000	1000
Absorbed current (A)	7	9.5	6.1	6.4	10	10.1	14	14	11.5
Output power (W)	34	125	184	42	151	314	77	235	419
General characteristics									
Rotor inertia (gcm ²)	75			115			120		
Number of rotor poles	4			4			8		
Ambient operating temperature (°C)	-30 → +70			-30 → +70			-30 → +70		
Service life (h)	20000			20000			20000		
Ball bearing	✓			✓			✓		
Weight (kg)	1.17			1.52			1.62		
Integrated software									
Applications software	✓			✓			✓		
Positioning mode	✓			✓			✓		
Speed mode	✓			✓			✓		
Torque mode	✓			✓			✓		
Inputs / Outputs									
Analog inputs (PWM and 0-10 V)	2			2			2		
Digital inputs	4			4			4		
(PWM) output	2			2			2		
Digital output	2			2			2		
IP54 over the whole motor apart from the shaft output. Versions with brake are IP20									
Accessory									
Starter kit, DCmind soft program and USB cable							79298008		

Product adaptations



- > Other specific applications software
- > Specific PC interface
- > Special cable length
- > Special shaft
- > Other connectors

Curves

Speed / Torque 80140 SMi21- Current / Torque 80140 SMi21

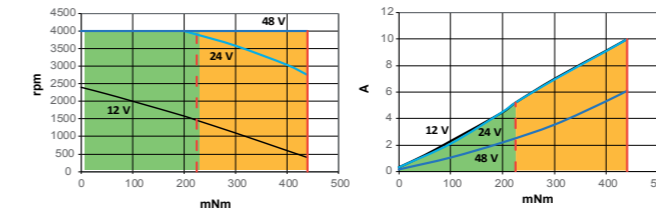

Speed / Torque 80180 SMi21 - Current / Torque 80180 SMi21

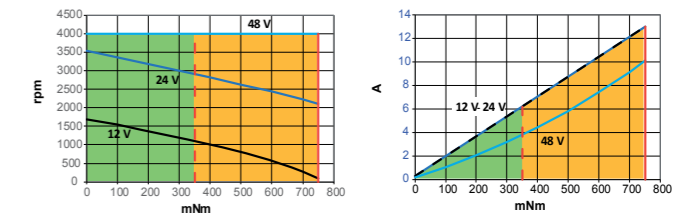

Speed / Torque 80280 SMi21- Current / Torque 80280 SMi21

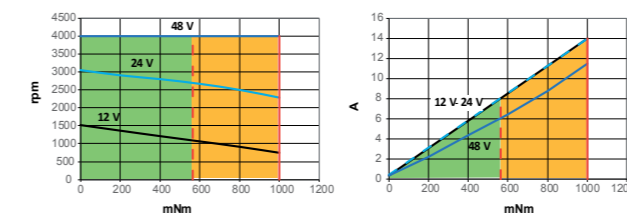

- Continuous running area
- Cycling running area
- Maximum continuous torque
- Maximum peak torque

Dimensions (mm)

80140 - 80180 - 80280 SMi21

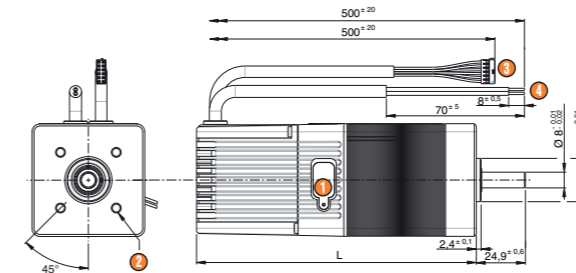

- USB connection type A or B
- 4 x M5 over Ø 40 depth 4.5
- Command cable 12 x AWG26
- Power cable 2 x AWG16

L: 80140: 123 max
L: 80180 / 80280: 143 max

More information: see page 16

Connection

Connector (Molex 0430251200)

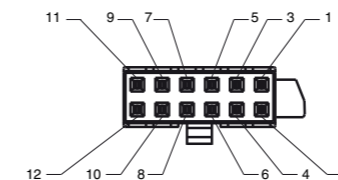

Pin	Logic cable		Power cable	
	Description	Wires color	Description	Wires color
1	Input 1 - logic	Green	+12 V _{DC} → 48 V _{DC}	Brown
2	Input 2 - logic	Yellow	0 V _{DC}	Blue
3	Input 3 - logic	White		
4	Input 4 - logic	White-brown		
5	Input 5 - analog	Blue		
6	Input 6 - analog	Orange		
7	0 V _{DC}	Black		
8	0 V _{DC}	White-black		
9	Output 1 - PWM	Brown		
10	Output 2 - PWM	Purple		
11	Output 3 - logic	Red		
12	Output 4 - logic	Grey		

User information

Notice available on website, please read it before use.

DC DIRECT DCmind BRUSHLESS TNi21 & SMi21

Dimensions (mm)

80140 - 80180 - 80280 - TNi21 version output cable with or without brake

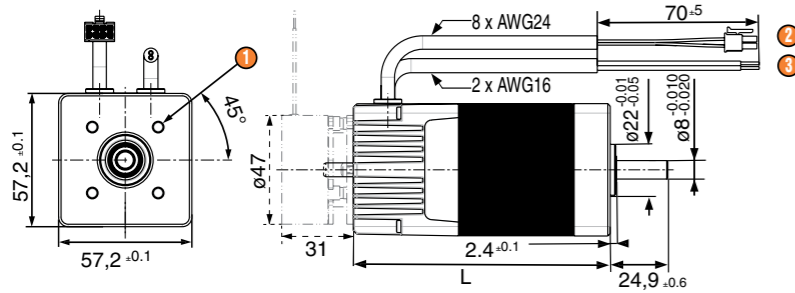

L 80140: 92 max.
L 80180: 112 max.
L 80280: 112 max.

- 1 4 x M5 at 90°, depth 6 over Ø 40
- 2 Command cable 8 x AWG24 / 500 mm
- 3 Power cable 2 x AWG16 / 500 mm

80140 - 80180 - TNi21 version connector M16 - 12 pins with or without brake

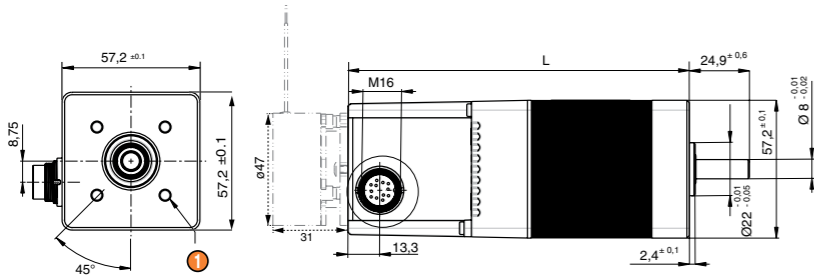

L 80140: 123 max.
L 80180: 143 max.

- 1 4 x M5 at 90°, depth 6 over Ø 40

80140 - 80180 - 80280 - SMi21 with or without brake

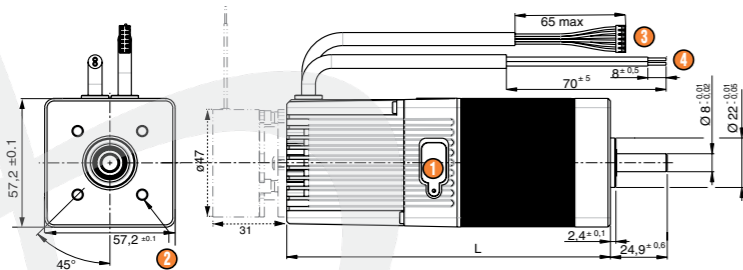

L 80140: 123 max.
L 80180: 143 max.
L 80280: 143 max.

- 1 USB connection type A or B
- 2 4 x M5 at 90°, depth 6 over Ø 40
- 3 Command cable 10 x AWG24 / 500 mm
- 4 Power cable 2 x AWG16 / 500 mm

DC GEARED DCmind BRUSHLESS TNi21

Dimensions (mm)

801495 - TNi21 + P52 with or without brake

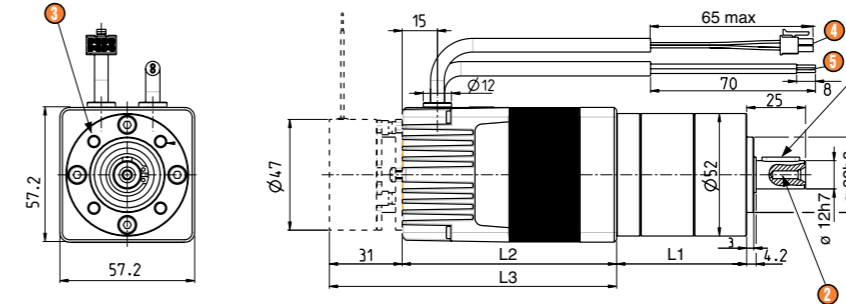

L1 1 stage: 55.3 ±0.5
L1 2 stages: 69.5 ±0.5
L1 3 stages: 83.7 ±0.5

L2 80140: 92 max.
L3 80140: 123 max.

- 1 Parallel key 4 x 4 x 16 DIN 6885 A
- 2 M4 x 10
- 3 4 x M5 at 90°, depth 10 over Ø 40
- 4 Command cable 8 x AWG24 / 500 mm
- 5 Power cable 2 x AWG16 / 500 mm

801496 - 801896 - TNi21 + P62 with or without brake

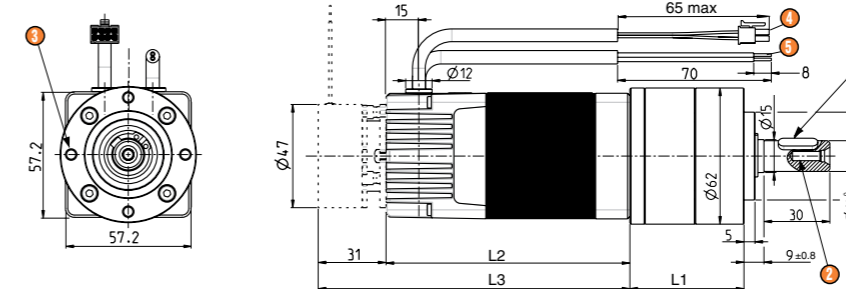

L1 1 stage: 52.1 ±0.7
L1 2 stages: 67.9 ±0.7
L1 3 stages: 83.8 ±0.7

L2 80140: 92 max.
L2 80180: 112 max.
L3 80140: 123 max.
L3 80180: 143 max.

- 1 Parallel key 5 x 5 x 18 DIN 6885 A
- 2 M5 x 12
- 3 4 x M5 at 90°, depth 10 over Ø 52
- 4 Command cable 8 x AWG24 / 500 mm
- 5 Power cable 2 x AWG16 / 500 mm

801897 - 802897 - TNi21 + P81 with or without brake

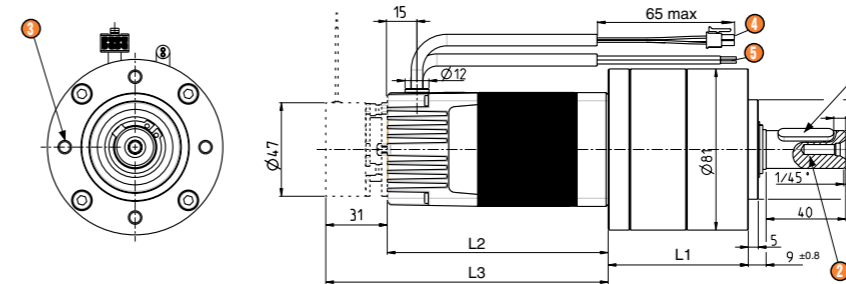

L1 1 stage: 70.5 ±0.6
L1 2 stages: 92.2 ±0.6
L1 3 stages: 113.8 ±0.6

L2 80180-80280: 112 max.
L3 80180-80280: 143 max.

- 1 Parallel key 6 x 6 x 28 DIN 6885 A
- 2 M6 x 16
- 3 4 x M6 at 90°, depth 12 over Ø 65
- 4 Command cable 8 x AWG24 / 500 mm
- 5 Power cable 2 x AWG16 / 500 mm

801410 - 801810 - 802810 - TNi21 + RAD10 with or without brake

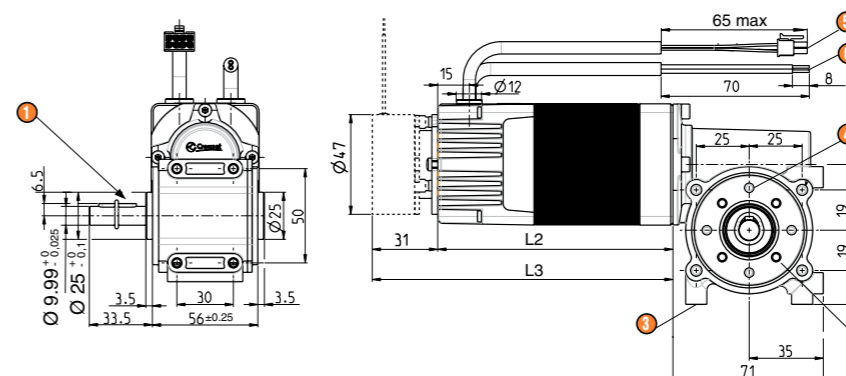

L2 80140: 92 max.
L2 80180-80280: 112 max.
L3 80140: 123 max.
L3 80180-80280: 143 max.

- 1 Parallele key 4 x 4 x 20 DIN 6885 A
- 2 4 x M4, depth 8 over Ø 36
- 3 8 x M5 depth 8
- 4 4 x Ø 3,8, depth 10 over Ø 40
- 5 Command cable 8 x AWG24 / 500 mm
- 6 Power cable 2 x AWG16 / 500 mm