

# DCmind: BRUSHLESS MOTORS

## Motors 34 to 192 W nominal output power range SMI21

- > Servomotor for position, speed and torque control applications
- > Very high power density
- > Built-in electronics with 6 inputs (2 of which are analog) and 4 outputs
- > Built-in 4096-pulse encoder
- > With application programs already debugged and saved in the motor
- > Expert programs can be used to adapt to the requirements of difficult applications
- > Parameters set on the PC via USB connection
- > Integrated bootloader for embedding special customer firmware



### Parts number

	34 to 94 W			40 to 145 W			82 to 192 W		
Type	80140 SMI21			80180 SMI21			80280 SMI21		
<b>Part numbers</b>									
IP65 option	80140043			80180044			80280001		
Holding torque brake 0.5 Nm option	80140044			80180045			80280002		
Nominal operating range (V <sub>DC</sub> )	12 - 48			12 - 48			12 - 48		
Min. max. operating range (V <sub>DC</sub> )	9 - 56			9 - 56			9 - 56		
<b>No-load characteristics</b>	12 V <sub>DC</sub>	24 V <sub>DC</sub>	48 V <sub>DC</sub>	12 V <sub>DC</sub>	24 V <sub>DC</sub>	48 V <sub>DC</sub>	12 V <sub>DC</sub>	24 V <sub>DC</sub>	48 V <sub>DC</sub>
Speed of rotation (rpm)	2400	4000	4000	1700	3500	4000	1500	3050	4000
Absorbed current (A)	0.3	0.3	0.2	0.3	0.33	0.2	0.38	0.44	0.35
<b>Nominal characteristics</b>	12 V <sub>DC</sub>	24 V <sub>DC</sub>	48 V <sub>DC</sub>	12 V <sub>DC</sub>	24 V <sub>DC</sub>	48 V <sub>DC</sub>	12 V <sub>DC</sub>	24 V <sub>DC</sub>	48 V <sub>DC</sub>
Speed (rpm)	1460	3900	4000	1100	2900	4000	1100	2863	4000
Torque (mNm)	225	225	225	350	350	350	685	565	460
Absorbed current (A)	5.2	5.2	2.6	5.65	5.40	3.65	10	8	5
Output power (W)	34	92	94	40	105	145	82	170	192
<b>Maximal characteristics</b>	12 V <sub>DC</sub>	24 V <sub>DC</sub>	48 V <sub>DC</sub>	12 V <sub>DC</sub>	24 V <sub>DC</sub>	48 V <sub>DC</sub>	12 V <sub>DC</sub>	24 V <sub>DC</sub>	48 V <sub>DC</sub>
Speed of rotation (rpm)	1100	3000	4000	1000	2400	4000	740	2250	4000
Torque (mNm)	300	400	440	400	600	750	1000	1000	1000
Absorbed current (A)	7	9.5	6.1	6.4	10	10.1	14	14	11.5
Output power (W)	34	125	184	42	151	314	77	235	419
<b>General characteristics</b>									
Rotor inertia (gcm <sup>2</sup> )	75			115			120		
Number of rotor poles	4			4			8		
Ambient operating temperature (°C)	-30 → +70			-30 → +70			-30 → +70		
Service life (h)	20000			20000			20000		
Ball bearing	✓			✓			✓		
Weight (kg)	1.17			1.52			1.62		
<b>Integrated software</b>									
Applications software	✓			✓			✓		
Positioning mode	✓			✓			✓		
Speed mode	✓			✓			✓		
Torque mode	✓			✓			✓		
<b>Inputs / Outputs</b>									
Analog inputs (PWM and 0-10 V)	2			2			2		
Digital inputs	4			4			4		
(PWM) output	2			2			2		
Digital output	2			2			2		
IP65 over the whole motor apart from the shaft output. Versions with brake are IP20									
<b>Accessory</b>									
Starter kit, DCmind soft program and USB cable							79298008		

### Product adaptations



- > Other specific applications software
- > Specific PC interface
- > Special cable length
- > Special shaft
- > Other connectors

## Curves

Speed / Torque 80140 SMI21- Current / Torque 80140 SMI21

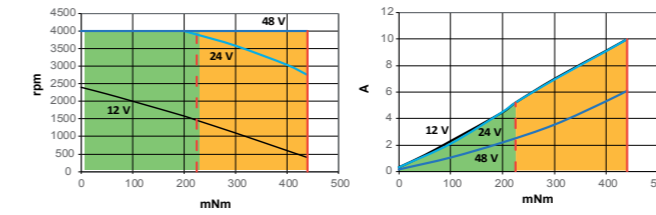

Speed / Torque 80180 SMI21 - Current / Torque 80180 SMI21

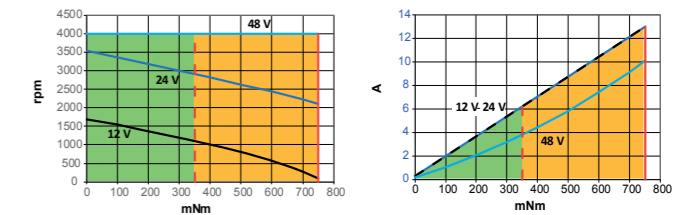

Speed / Torque 80280 SMI21- Current / Torque 80280 SMI21

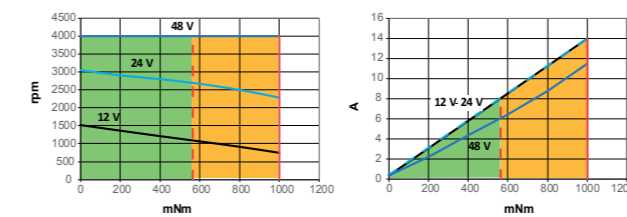

- Continuous running area
- Cycling running area
- Maximum continuous torque
- Maximum peak torque

### Dimensions (mm)

80140 - 80180 - 80280 SMI21

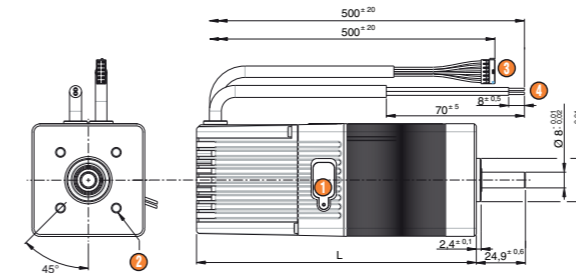

- USB connection type A or B
- 4 x M5 over Ø 40 depth 4.5
- Command cable 12 x AWG26
- Power cable 2 x AWG16

L: 80140: 123 max  
L: 80180 / 80280: 143 max

More information: see page 16

### Connection

Connector (Molex 0430251200)

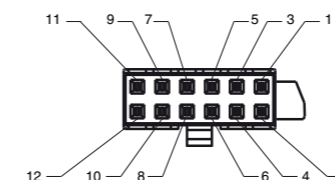

Pin	Logic cable		Power cable	
	Description	Wires color	Description	Wires color
1	Input 1 - logic	Green	+12 V <sub>DC</sub> → 48 V <sub>DC</sub>	Brown
2	Input 2 - logic	Yellow	0 V <sub>DC</sub>	Blue
3	Input 3 - logic	White		
4	Input 4 - logic	White-brown		
5	Input 5 - analog	Blue		
6	Input 6 - analog	Orange		
7	0 V <sub>DC</sub>	Black		
8	0 V <sub>DC</sub>	White-black		
9	Output 1 - PWM	Brown		
10	Output 2 - PWM	Purple		
11	Output 3 - logic	Red		
12	Output 4 - logic	Grey		

### User information

Notice available on website, please read it before use.

# GEARBOXES FOR DCmind BRUHLESS RANGE

4 to 120 Nm

- > Planetary and worm gearboxes
- > Shafts on ball bearings
- > Long service life
- > IP65



Gearboxes	Planetary Ø 52	Planetary Ø 62	Planetary Ø 81	Worm
Type	810495	810496	810497	810410
Associated motors	Part number	Part number	Part number	Part number
80140 TNi21	801495 TNi21	801496 TNi21	801897 TNi21	801410 TNi21
80180 TNi21		801896 TNi21	802897 TNi21	801810 TNi21
80280 TNi21				802810 TNi21
80140 SMi21	801495 SMi21	801496 SMi21	801897 SMi21	801410 SMi21
80180 SMi21		801896 SMi21	802897 SMi21	801810 SMi21
80280 SMi21				802810 SMi21
Gearbox characteristics	1	2	3	
Number of stages	4	12	25	1
Maximum permitted torque (Nm)	0.8	0.75	0.7	0.6 → 0.3
Efficiency	6	10	15	10
Axial dynamic load (daN)	20	32	45	15
Radial dynamic load (daN)	-20 → +70°C			-20 → +70°C
Operating temperature	0.7	0.8	1.1	0.7
Weight (kg)	6.75	25	93	5 - 10 - 20 - 30 - 50
Standard reduction ratios		46	169	
		308		
Other ratios possible				15 - 100

Other ratios possible

**Comments**

**Ø 52 planetary gearbox:** Metal gears on all stages. IP65 apart from the output shaft.

**Ø 62 planetary gearbox:** On the first stage, the planet gears are made of composite materials which improve efficiency and service life. On the other stages, the metal gears turn on needle bearings. IP65 apart from the output shaft.

**Ø 81 planetary gearbox:** All gears are metal and turn on needle bearings, resulting in excellent robustness and a very long service life. IP65 apart from the output shaft.

**Worm gearbox:** This gearbox combines a tempered steel worm and a hard bronze helical gear wheel, thus ensuring a long service life. The wheel is coated with grease, ensuring an excellent slip coefficient and good heat dissipation. O-rings and lipseals are used in combination with a compression spring to create a tight seal at the gearbox output shaft and the motor input shaft. IP65 gearbox.

The casing is made of aluminium to maximise heat exchanges with its supporting surface on the machine. However, due to the high power that can be transmitted by this gearbox and the low efficiency inherent in large worm gearbox reduction ratios, make sure that the gearbox casing temperature does not exceed 75°C during operation.

The output shaft can be placed on the right or left, or can be a double shaft (shaft output on both sides).

Made to order products, available on request

- > Special shafts
- > Other reduction ratios
- > Other fixing holes
- > Special mounting flange

## Dimensions (mm)

Planetary gearbox Ø 52 (810495)

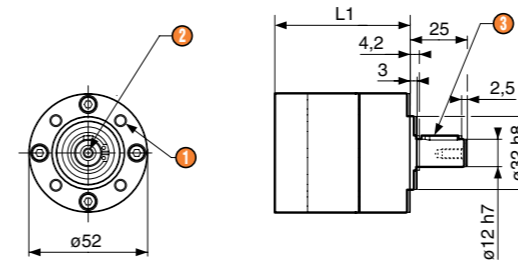

- 1 4 x M5 at 90°, depth 10 over Ø 40
- 2 M4 x 10
- 3 Parallel key 4 x 4 x 16 DIN 6885 A

L1 1 stage: 55.3 ± 0.5  
L1 2 stages: 69.5 ± 0.5  
L1 3 stages: 83.7 ± 0.5

Planetary gearbox Ø 62 (810496)

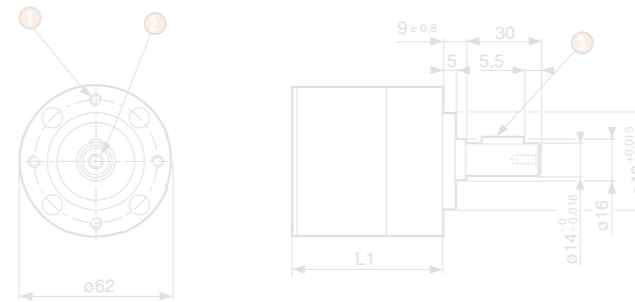

- 1 4 x M5 at 90°, depth 10 over Ø 52
- 2 M5, depth 12.5
- 3 Parallel key 5 x 5 x 18 DIN 6885 A

L1 1 stage: 52.1 ± 0.7  
L1 2 stages: 67.9 ± 0.7  
L1 3 stages: 83.8 ± 0.7

Planetary gearbox Ø 81 (810497)

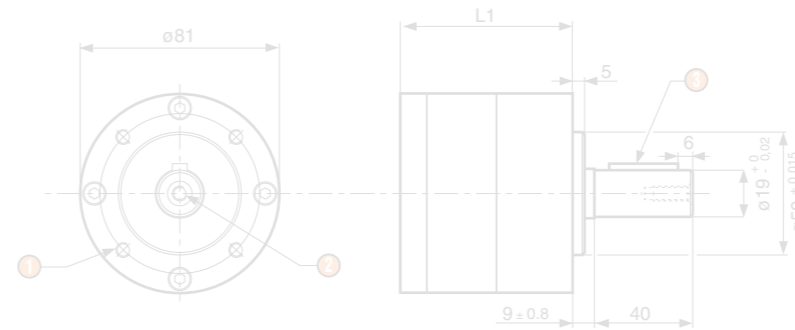

- 1 4 x M6, depth 12 over Ø 65
- 2 M6 x 16
- 3 Parallel key 6 x 6 x 28 DIN 6885 A

L1 1 stage: 70.5 ± 0.6  
L1 2 stages: 92.2 ± 0.6  
L1 3 stages: 113.8 ± 0.6

Worm gearbox RAD10

Version with output shaft on left

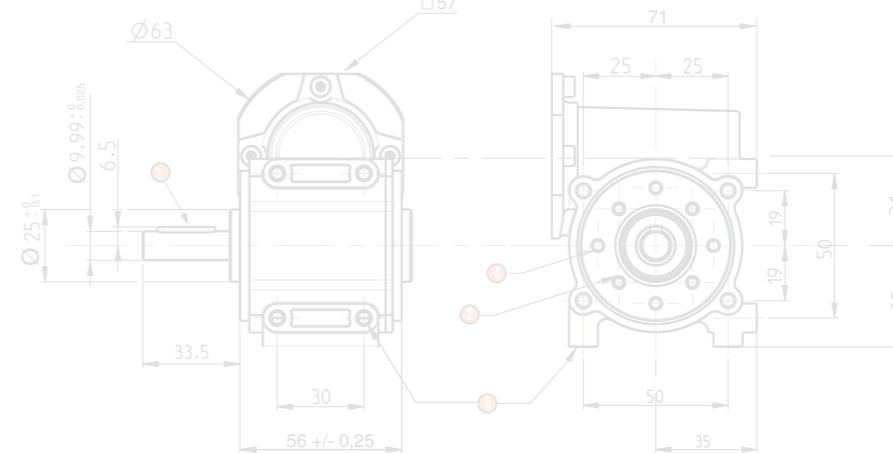

- 1 Parallel key 4 x 4 x 20 DIN6885
- 2 4 x M4, depth 8 over Ø 36
- 3 8 x M5, depth 8
- 4 4 x Ø 3.8 depth 10 over Ø 40

The left-hand and right-hand sides of the gearbox are identical.

## DC GEARED DCmind BRUSHLESS TNi21

### Dimensions (mm)

801495 - TNi21 + P52 M16 connector with or without brake

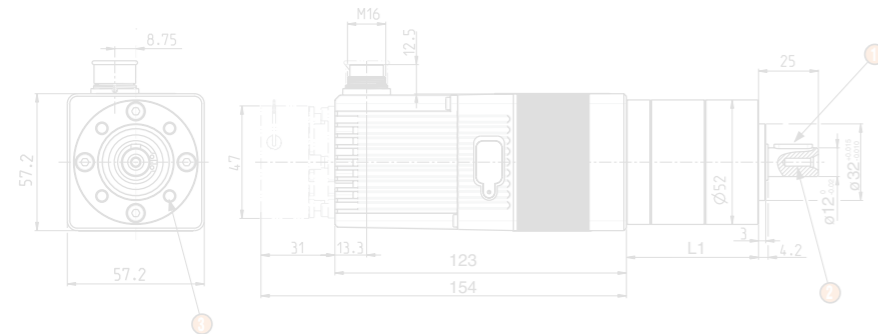

- L1 1 stage: 55.3 ±0.5
- L1 2 stages: 69.5 ±0.5
- L1 3 stages: 83.7 ±0.5

- 1 Parallel key 4 x 4 x 16 DIN 6885 A
- 2 M4 x 10
- 3 4 x M5 at 90°, depth 10 over Ø 40

801496 - 801896 - TNi21 + P62 M16 connector with or without brake

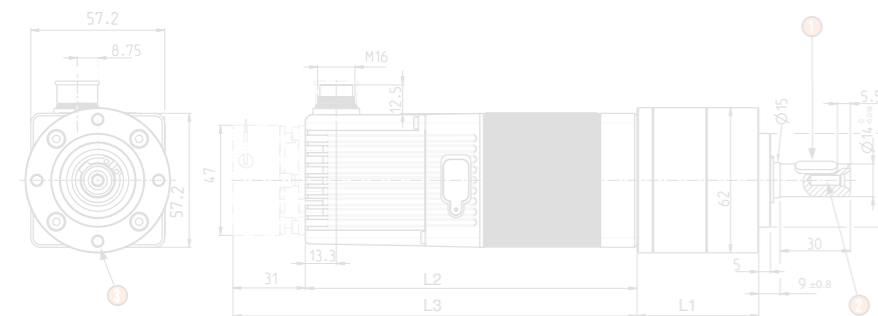

- L1 1 stage: 52.1 ±0.7
- L1 2 stages: 67.9 ±0.7
- L1 3 stages: 83.8 ±0.7

- L2 80140: 123 max.
- L2 80180: 143 max.
- L3 80140: 154 max.
- L3 80180: 174 max.

- 1 Parallel key 5 x 5 x 18 DIN 6885 A
- 2 M5 x 12
- 3 4 x M5 at 90°, depth 10 over Ø 52

801897 - TNi21 + P81 M16 connector with or without brake

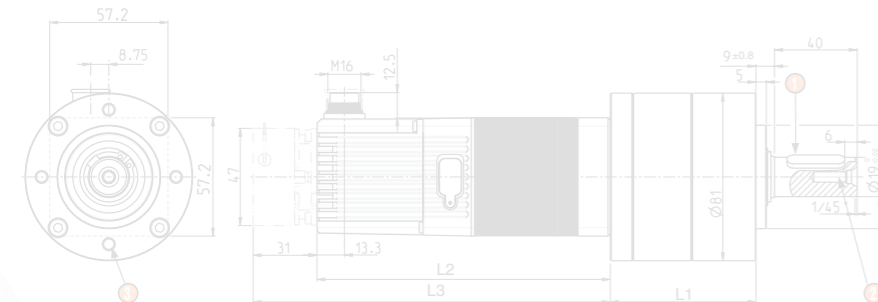

- L1 1 stage: 70.5 ±0.6
- L1 2 stages: 92.2 ±0.6
- L1 3 stages: 113.8 ±0.6

- L2 80180: 143 max.
- L3 80180: 174 max.

- 1 Parallel key 6 x 6 x 28 DIN 6885 A
- 2 M6 x 16
- 3 4 x M6, depth 12 over Ø 65

801410 - 801810 - 802810 - TNi21 + RAD10 M16 connector with or without brake

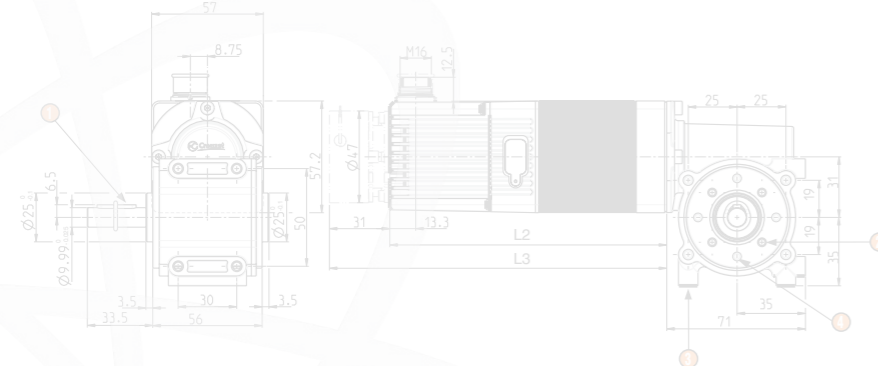

- L2 80140: 123 max.
- L2 80180-80280: 143 max.
- L3 80140: 154 max.
- L3 80180-80280: 174 max.

- 1 Parallel key 4 x 4 x 20 DIN 6885 A
- 2 4 x M4, depth 8 over Ø 36
- 3 8 x M5, depth 8
- 4 4 x 3.8, depth 10 over Ø 40

## DC GEARED DCmind BRUSHLESS SMi21

### Dimensions (mm)

801495 - SMi21 + P52 with or without brake

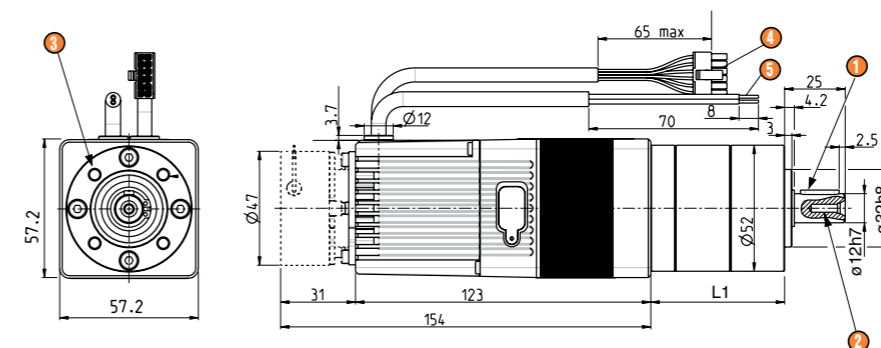

- L1 1 stage: 55.3 ±0.5
- L1 2 stages: 69.5 ±0.5
- L1 3 stages: 83.7 ±0.5

- 1 Parallel key 4 x 4 x 16 DIN 6885 A
- 2 M4 x 10
- 3 4 x M5 at 90°, depth 10 over Ø 40
- 4 Command cable 12 x AWG26 / 500 mm
- 5 Power cable 2 x AWG16 / 500 mm

801496 - 801896 - SMi21 + P62 with or without brake

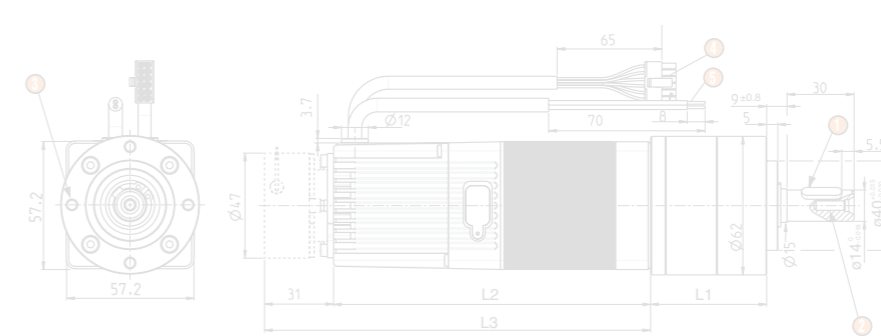

- L1 1 stage: 52.1 ±0.7
- L1 2 stages: 67.9 ±0.7
- L1 3 stages: 83.8 ±0.7

- L2 80140: 123 max.
- L2 80180: 143 max.

- L3 80140: 154 max.
- L3 80180: 174 max.

- 1 Parallel key 5 x 5 x 18 DIN 6885 A
- 2 M5 x 12
- 3 4 x M5 at 90°, depth 10 over Ø 52
- 4 Command cable 12 x AWG26 / 500 mm
- 5 Power cable 2 x AWG16 / 500 mm

801897 - 802897 - SMi21 + P81 with or without brake

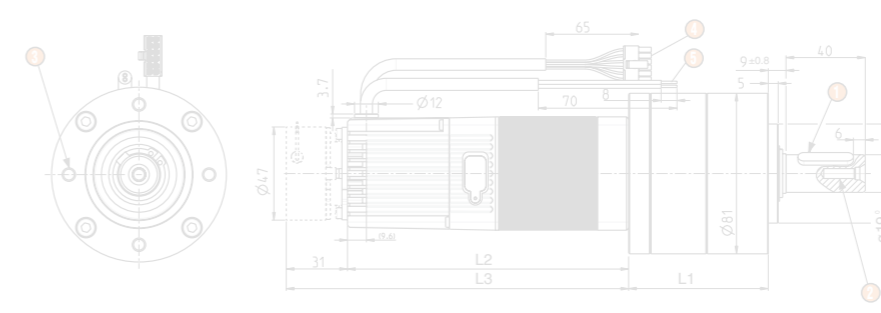

- L1 1 stage: 70.5 ±0.6
- L1 2 stages: 92.2 ±0.6
- L1 3 stages: 113.8 ±0.6

- L2 80180 - 80280: 143 max.
- L3 80180 - 80280: 174 max.

- 1 Parallel key 6 x 6 x 28 DIN 6885 A
- 2 M6 x 16
- 3 4 x M6 at 90°, depth 12 over Ø 65
- 4 Command cable 12 x AWG26 / 500 mm
- 5 Power cable 2 x AWG16 / 500 mm

801410 - 801810 - 802810 - SMi21 + RAD10 with or without brake

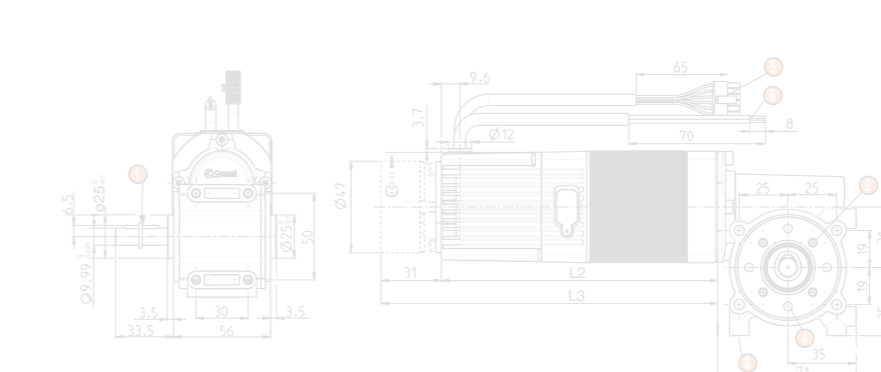

- L2 80140: 123 max.
- L2 80180 - 80280: 143 max.
- L3 80140: 154 max.
- L3 80180 - 80280: 174 max.

- 1 Parallel key 4 x 4 x 20 DIN 6885 A
- 2 4 x M4, depth 8 over Ø 36
- 3 8 x M5, depth 8
- 4 4 x Ø 3.8, depth 10 over Ø 40
- 5 Command cable 12 x AWG26 / 500 mm
- 6 Power cable 2 x AWG16 / 500 mm