

**Description**

The AZBH10A4 PWM servo drive is designed to drive brushless DC motors at a high switching frequency. To increase system reliability and to reduce cabling costs, the drive is designed for direct integration into your PCB. The AZBH10A4 is fully protected against over-voltage, under-voltage, over-current, over-heating, and short-circuits. A single digital output indicates operating status. The drive interfaces with digital controllers that have analog  $\pm 10V$  output. The AZBH10A4 utilizes Hall Sensor feedback for velocity control. This servo drive requires only a single unregulated isolated DC power supply, and is fully RoHS (Reduction of Hazardous Substances) compliant.

See Part Numbering Information on last page of datasheet for additional ordering options. The AZ Series Hardware Installation Manual is available for download at [www.a-m-c.com](http://www.a-m-c.com).

**Power Range**

Peak Current	10 A
Continuous Current	5 A
Supply Voltage	10 - 36 VDC



**Features**

- ▲ Four Quadrant Regenerative Operation
- ▲ Direct Board-to-Board Integration
- ▲ Lightweight
- ▲ High Switching Frequency
- ▲ Wide Temperature Range
- ▲ Differential Input Command
- ▲ Digital Fault Output Monitor
- ▲ Current Monitor Output
- ▲ Hall Velocity Mode
- ▲ Compact Size
- ▲ High Power Density
- ▲ 12VDC Operation

**HARDWARE PROTECTION**

- Over-Voltage
- Under-Voltage
- Over-Current
- Over-Temperature
- Short-circuit (phase-phase)
- Short-circuit (phase-ground)

**INPUTS/OUTPUTS**

- Digital Fault Output
- Digital Inhibit Input
- Analog Current Monitor
- Analog Command Input

**FEEDBACK SUPPORTED**

- Hall Sensors

**MODES OF OPERATION**

- Hall Velocity

**COMMUTATION**

- Trapezoidal

**MOTORS SUPPORTED**

- Three Phase (Brushless)

**COMMAND SOURCE**

- $\pm 10 V$  Analog

**COMPLIANCES & AGENCY APPROVALS**

- RoHS
- UL/cUL Pending
- CE Pending

**BLOCK DIAGRAM**

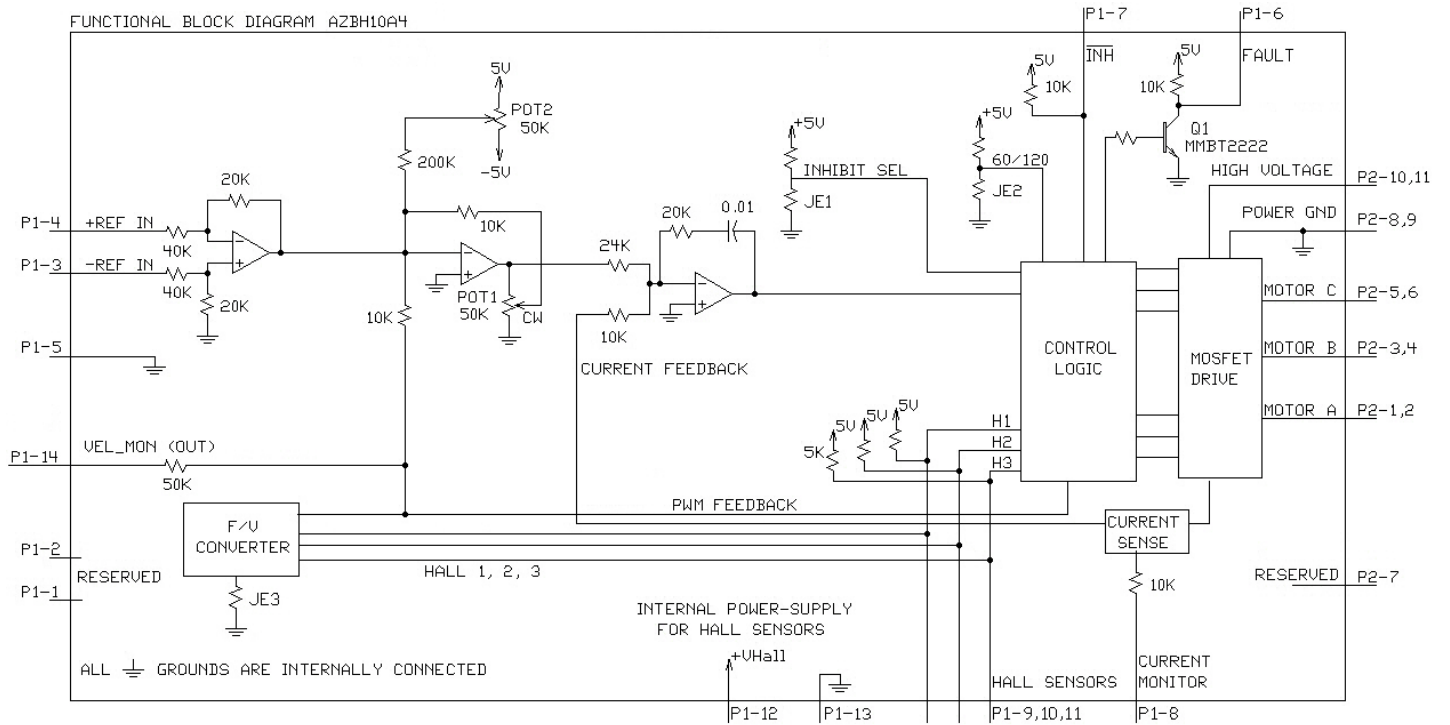

**Information on Approvals and Compliances**



RoHS (Reduction of Hazardous Substances) is intended to prevent hazardous substances such as lead from being manufactured in electrical and electronic equipment.

**SPECIFICATIONS**

Power Specifications		
Description	Units	Value
DC Supply Voltage Range	VDC	10 - 36
DC Bus Under Voltage Limit	VDC	8
DC Bus Over Voltage Limit	VDC	40
Maximum Peak Output Current <sup>1</sup>	A	10
Maximum Continuous Output Current	A	5
Maximum Continuous Output Power	W	171
Maximum Power Dissipation at Continuous Current	W	9
Minimum Load Inductance (Line-To-Line) <sup>2</sup>	μH	100
Internal Bus Capacitance <sup>3</sup>	μF	23.5
Low Voltage Supply Outputs	-	+5 VDC (30 mA)
Maximum Output PWM Duty Cycle	%	92 (±3%)
Switching Frequency	kHz	40
Control Specifications		
Description	Units	Value
Command Sources	-	±10 V Analog
Feedback Supported	-	Halls
Commutation Methods	-	Trapezoidal
Modes of Operation	-	Hall Velocity
Motors Supported	-	Three Phase (Brushless)
Hardware Protection	-	Invalid Commutation Feedback, Over Current, Over Temperature, Over Voltage, Under Voltage, Short Circuit (Phase-Phase & Phase-Ground)
Mechanical Specifications		
Description	Units	Value
Agency Approvals	-	RoHS, UL/cUL Pending, CE Pending
Size (H x W x D)	mm (in)	43.2 x 38.1 x 9.4 (1.70 x 1.50 x 0.37)
Weight	g (oz)	9.0 (0.32)
Operating Temperature Range <sup>4</sup>	°C (°F)	0 - 85 (32 - 185)
Storage Temperature Range	°C (°F)	-40 - 85 (-40 - 185)
Relative Humidity	-	0 - 90% Non-Condensing
Form Factor	-	PCB Mounted
P1 Connector	-	14-pin, 1.27 mm spaced header
P2 Connector	-	12-pin, 1.27 mm spaced header

**Notes**

1. Maximum duration of peak current is ~2 seconds. Peak RMS value must not exceed continuous current rating of the drive.
2. Lower inductance is acceptable for bus voltages well below maximum. Use external inductance to meet requirements.
3. Requires a minimum of 47 μF external bus capacitance between the DC Supply and Power Ground.
4. Additional cooling and/or heatsink may be required to achieve rated performance.

**PIN FUNCTIONS**

P1 - Signal Connector			
Pin	Name	Description / Notes	I/O
1	RESERVED	Reserved	-
2	RESERVED		-
3	-REF IN	Differential Reference Input ( $\pm 10$ V Operating Range, $\pm 15$ V Maximum Input)	I
4	+REF IN	Differential Reference Input ( $\pm 10$ V Operating Range, $\pm 15$ V Maximum Input)	I
5	SIGNAL GND	Signal Ground (Common With Power Ground).	GND
6	FAULT OUT	TTL level (+5 V) output becomes high when power devices are disabled due to at least one of the following conditions: inhibit, invalid Hall state, output short circuit, over voltage, over temperature, power-up reset.	O
7	INHIBIT IN	TTL level (+5 V) inhibit/enable input. Leave open to enable drive. Pull to ground to inhibit drive. Inhibit turns off all power devices.	I
8	CURRENT MONITOR	Current Monitor. Analog output signal proportional to the actual current output. Scaling is 2 A/V. Measure relative to signal ground.	O
9	HALL 3	Single-ended Hall/Commutation Sensor Inputs (+5 V logic level)	I
10	HALL 2		I
11	HALL 1		I
12	+V HALL OUT	Low Power Supply For Hall Sensors (+5 V @ 30 mA). Referenced to signal ground. Short circuit protected.	O
13	SIGNAL GND	Signal Ground (Common With Power Ground).	GND
14	VEL MONITOR OUT	Velocity Monitor ( $\pm 10$ V range). Analog output proportional to motor speed. In Hall Velocity mode, output is proportional to the electrical cycle frequency. Hall Velocity scaling is 100 Hz/V.	O/I

P2 - Power Connector			
Pin	Name	Description / Notes	I/O
1	MOTOR A	Motor Phase Outputs. Current output distributed equally across 2 pins per motor phase, 3A continuous current carrying capacity per pin.	O
2	MOTOR A		O
3	MOTOR B		O
4	MOTOR B		O
5	MOTOR C		O
6	MOTOR C		O
7	RESERVED	Reserved	-
8	PWR GND	Power Ground (Common With Signal Ground). 3A Continuous Current Rating Per Pin	GND
9	PWR GND		GND
10	HV IN	DC Power Input. 3A Continuous Current Rating Per Pin. Requires a minimum of 47 $\mu$ F external capacitance between HV IN and PWR GND pins.	I
11	HV IN		I
12	RESERVED	Reserved	-

## HARDWARE SETTINGS

### Jumper Settings

Jumpers are SMT, 0 ohm resistors located on the underside of the drive PCB. By default, the drive is configured with the jumpers installed. Typical drive operation will not require the jumpers to be removed. Please contact the factory before jumper removal.

Jumper	Description	Configuration	
		Not Installed	Installed (default)
JE1	Inhibit logic. Sets the logic level of inhibit pins. Labeled JE1 on the PCB of the drive.	Low Enable	Low Inhibit
JE3	Velocity feedback polarity. Changes the polarity of the internal feedback signal and the velocity monitor output signal. Inversion of the feedback polarity may be required to prevent a motor run-away condition.	Inverted	Standard

### Potentiometer Functions

Potentiometers are located between the PCB and the drive baseplate, and are accessible from the side. Potentiometers are approximately linear and have 12 active turns with 1 inactive turn on each end.

Potentiometer	Description	Turning CW
1	Loop gain adjustment for Hall velocity mode. Located closest to the corner of the PCB.	Increases gain
2	Offset. Used to adjust any imbalance in the input signal or in the amplifier. Located furthest from the corner of the PCB.	Adjusts offset in negative direction

**MECHANICAL INFORMATION**

**P1 - Signal Connector**

Connector Information		14-pin, 1.27 mm spaced header
Mating Connector	Details	Samtec: RSM-114-02-L-S
	Included with Drive	No

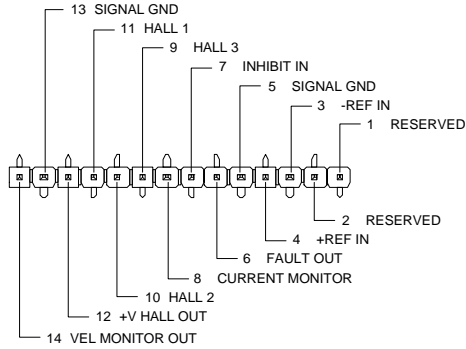

**P2 - Power Connector**

Connector Information		12-pin, 1.27 mm spaced header
Mating Connector	Details	Samtec: RSM-112-02-L-S
	Included with Drive	No

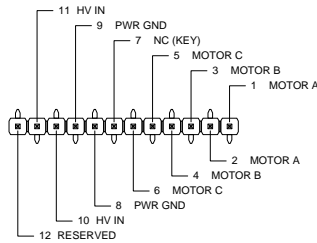

**MOUNTING DIMENSIONS**

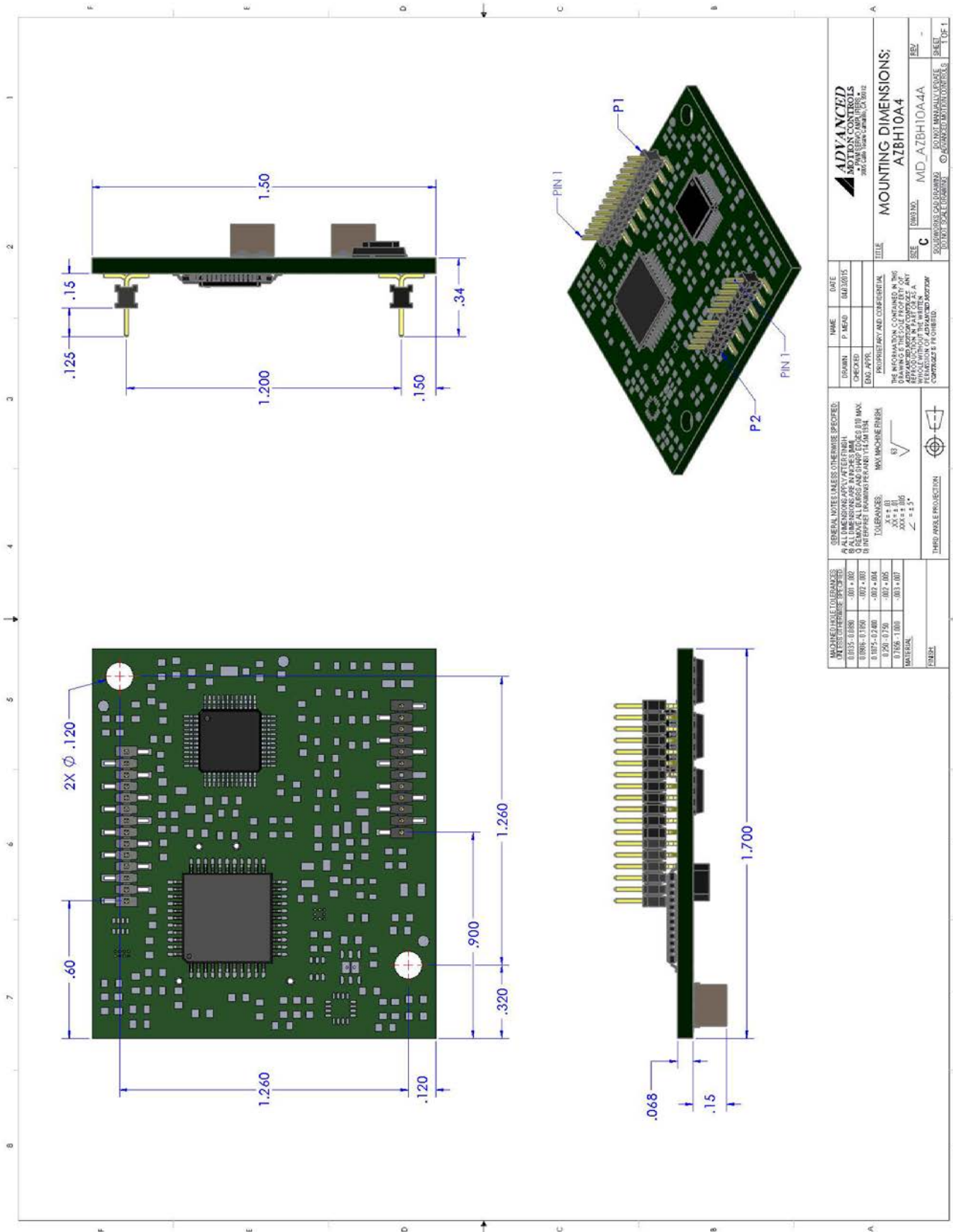

NAME	DATE
ADVANCED MOTION CONTROLS	04/20/15
DESIGNED BY	MD AZBH10A4A
CHECKED BY	
ENG. APPROV.	

DESCRIPTION	DATE
REV. C	04/20/15
REV. B	
REV. A	

GENERAL NOTES (UNLESS OTHERWISE SPECIFIED):
A ALL DIMENSIONS ARE IN INCHES UNLESS OTHERWISE SPECIFIED
B ALL DIMENSIONS ARE TO CENTER UNLESS OTHERWISE SPECIFIED
C DIMENSIONS ARE TO DIMENSION LINES UNLESS OTHERWISE SPECIFIED
D FINISH ALL DIMENSIONS AND HORIZONTAL DIMENSIONS TO MAX. UNLESS OTHERWISE SPECIFIED
E DIMENSIONS ARE TO DIMENSION LINES UNLESS OTHERWISE SPECIFIED
F DIMENSIONS ARE TO DIMENSION LINES UNLESS OTHERWISE SPECIFIED
G DIMENSIONS ARE TO DIMENSION LINES UNLESS OTHERWISE SPECIFIED
H DIMENSIONS ARE TO DIMENSION LINES UNLESS OTHERWISE SPECIFIED
I DIMENSIONS ARE TO DIMENSION LINES UNLESS OTHERWISE SPECIFIED
J DIMENSIONS ARE TO DIMENSION LINES UNLESS OTHERWISE SPECIFIED
K DIMENSIONS ARE TO DIMENSION LINES UNLESS OTHERWISE SPECIFIED
L DIMENSIONS ARE TO DIMENSION LINES UNLESS OTHERWISE SPECIFIED
M DIMENSIONS ARE TO DIMENSION LINES UNLESS OTHERWISE SPECIFIED
N DIMENSIONS ARE TO DIMENSION LINES UNLESS OTHERWISE SPECIFIED
O DIMENSIONS ARE TO DIMENSION LINES UNLESS OTHERWISE SPECIFIED
P DIMENSIONS ARE TO DIMENSION LINES UNLESS OTHERWISE SPECIFIED
Q DIMENSIONS ARE TO DIMENSION LINES UNLESS OTHERWISE SPECIFIED
R DIMENSIONS ARE TO DIMENSION LINES UNLESS OTHERWISE SPECIFIED
S DIMENSIONS ARE TO DIMENSION LINES UNLESS OTHERWISE SPECIFIED
T DIMENSIONS ARE TO DIMENSION LINES UNLESS OTHERWISE SPECIFIED
U DIMENSIONS ARE TO DIMENSION LINES UNLESS OTHERWISE SPECIFIED
V DIMENSIONS ARE TO DIMENSION LINES UNLESS OTHERWISE SPECIFIED
W DIMENSIONS ARE TO DIMENSION LINES UNLESS OTHERWISE SPECIFIED
X DIMENSIONS ARE TO DIMENSION LINES UNLESS OTHERWISE SPECIFIED
Y DIMENSIONS ARE TO DIMENSION LINES UNLESS OTHERWISE SPECIFIED
Z DIMENSIONS ARE TO DIMENSION LINES UNLESS OTHERWISE SPECIFIED

  

THIRD ANGLE PROJECTION
ISO
ASME
ANSI
BS
JIS
GB
DIN
ISO
ASME
ANSI
BS
JIS
GB
DIN

UNLESS OTHERWISE SPECIFIED:	
0.0015 - 0.0030	0.01 ± 0.02
0.0030 - 0.0045	0.02 ± 0.03
0.0045 - 0.0060	0.03 ± 0.04
0.0060 - 0.0075	0.04 ± 0.05
0.0075 - 0.0090	0.05 ± 0.06
0.0090 - 0.0105	0.06 ± 0.07
0.0105 - 0.0120	0.07 ± 0.08
0.0120 - 0.0135	0.08 ± 0.09
0.0135 - 0.0150	0.09 ± 0.10
0.0150 - 0.0165	0.10 ± 0.11
0.0165 - 0.0180	0.11 ± 0.12
0.0180 - 0.0195	0.12 ± 0.13
0.0195 - 0.0210	0.13 ± 0.14
0.0210 - 0.0225	0.14 ± 0.15
0.0225 - 0.0240	0.15 ± 0.16
0.0240 - 0.0255	0.16 ± 0.17
0.0255 - 0.0270	0.17 ± 0.18
0.0270 - 0.0285	0.18 ± 0.19
0.0285 - 0.0300	0.19 ± 0.20
0.0300 - 0.0315	0.20 ± 0.21
0.0315 - 0.0330	0.21 ± 0.22
0.0330 - 0.0345	0.22 ± 0.23
0.0345 - 0.0360	0.23 ± 0.24
0.0360 - 0.0375	0.24 ± 0.25
0.0375 - 0.0390	0.25 ± 0.26
0.0390 - 0.0405	0.26 ± 0.27
0.0405 - 0.0420	0.27 ± 0.28
0.0420 - 0.0435	0.28 ± 0.29
0.0435 - 0.0450	0.29 ± 0.30
0.0450 - 0.0465	0.30 ± 0.31
0.0465 - 0.0480	0.31 ± 0.32
0.0480 - 0.0495	0.32 ± 0.33
0.0495 - 0.0510	0.33 ± 0.34
0.0510 - 0.0525	0.34 ± 0.35
0.0525 - 0.0540	0.35 ± 0.36
0.0540 - 0.0555	0.36 ± 0.37
0.0555 - 0.0570	0.37 ± 0.38
0.0570 - 0.0585	0.38 ± 0.39
0.0585 - 0.0600	0.39 ± 0.40
0.0600 - 0.0615	0.40 ± 0.41
0.0615 - 0.0630	0.41 ± 0.42
0.0630 - 0.0645	0.42 ± 0.43
0.0645 - 0.0660	0.43 ± 0.44
0.0660 - 0.0675	0.44 ± 0.45
0.0675 - 0.0690	0.45 ± 0.46
0.0690 - 0.0705	0.46 ± 0.47
0.0705 - 0.0720	0.47 ± 0.48
0.0720 - 0.0735	0.48 ± 0.49
0.0735 - 0.0750	0.49 ± 0.50
0.0750 - 0.0765	0.50 ± 0.51
0.0765 - 0.0780	0.51 ± 0.52
0.0780 - 0.0795	0.52 ± 0.53
0.0795 - 0.0810	0.53 ± 0.54
0.0810 - 0.0825	0.54 ± 0.55
0.0825 - 0.0840	0.55 ± 0.56
0.0840 - 0.0855	0.56 ± 0.57
0.0855 - 0.0870	0.57 ± 0.58
0.0870 - 0.0885	0.58 ± 0.59
0.0885 - 0.0900	0.59 ± 0.60
0.0900 - 0.0915	0.60 ± 0.61
0.0915 - 0.0930	0.61 ± 0.62
0.0930 - 0.0945	0.62 ± 0.63
0.0945 - 0.0960	0.63 ± 0.64
0.0960 - 0.0975	0.64 ± 0.65
0.0975 - 0.0990	0.65 ± 0.66
0.0990 - 0.1005	0.66 ± 0.67
0.1005 - 0.1020	0.67 ± 0.68
0.1020 - 0.1035	0.68 ± 0.69
0.1035 - 0.1050	0.69 ± 0.70
0.1050 - 0.1065	0.70 ± 0.71
0.1065 - 0.1080	0.71 ± 0.72
0.1080 - 0.1095	0.72 ± 0.73
0.1095 - 0.1110	0.73 ± 0.74
0.1110 - 0.1125	0.74 ± 0.75
0.1125 - 0.1140	0.75 ± 0.76
0.1140 - 0.1155	0.76 ± 0.77
0.1155 - 0.1170	0.77 ± 0.78
0.1170 - 0.1185	0.78 ± 0.79
0.1185 - 0.1200	0.79 ± 0.80
0.1200 - 0.1215	0.80 ± 0.81
0.1215 - 0.1230	0.81 ± 0.82
0.1230 - 0.1245	0.82 ± 0.83
0.1245 - 0.1260	0.83 ± 0.84
0.1260 - 0.1275	0.84 ± 0.85
0.1275 - 0.1290	0.85 ± 0.86
0.1290 - 0.1305	0.86 ± 0.87
0.1305 - 0.1320	0.87 ± 0.88
0.1320 - 0.1335	0.88 ± 0.89
0.1335 - 0.1350	0.89 ± 0.90
0.1350 - 0.1365	0.90 ± 0.91
0.1365 - 0.1380	0.91 ± 0.92
0.1380 - 0.1395	0.92 ± 0.93
0.1395 - 0.1410	0.93 ± 0.94
0.1410 - 0.1425	0.94 ± 0.95
0.1425 - 0.1440	0.95 ± 0.96
0.1440 - 0.1455	0.96 ± 0.97
0.1455 - 0.1470	0.97 ± 0.98
0.1470 - 0.1485	0.98 ± 0.99
0.1485 - 0.1500	0.99 ± 1.00

**PART NUMBERING INFORMATION**

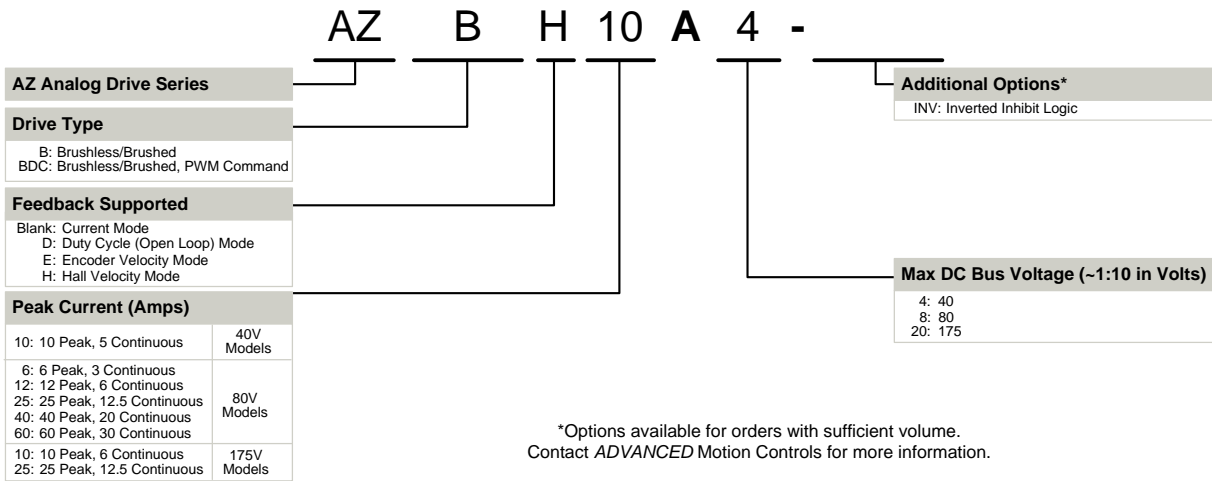

*ADVANCED* Motion Controls AZ series of servo drives are available in many configurations. Note that not all possible part number combinations are offered as standard drives. All models listed in the selection tables of the website are readily available, standard product offerings.

*ADVANCED* Motion Controls also has the capability to promptly develop and deliver specified products for OEMs with volume requests. Our Applications and Engineering Departments will work closely with your design team through all stages of development in order to provide the best servo drive solution for your system. Equipped with on-site manufacturing for quick-turn customs capabilities, *ADVANCED* Motion Controls utilizes our years of engineering and manufacturing expertise to decrease your costs and time-to-market while increasing system quality and reliability.

**Examples of Modifications and Customized Products**

- |   |  |
|---|--|
| <ul style="list-style-type: none"> <li>▲ Integration of Drive into Motor Housing</li> <li>▲ Mount OEM PCB onto Drive Without Cables</li> <li>▲ Multi-axis Configuration for Compact System</li> <li>▲ Custom PCB and Baseplate for Optimized Footprint</li> <li>▲ RTV/Epoxy Components for High Vibration</li> <li>▲ OEM Specified Connectors for Instant Compatibility</li> <li>▲ OEM Specified Silkscreen for Custom Appearance</li> <li>▲ Increased Thermal Limits for High Temp. Operation</li> </ul> | <ul style="list-style-type: none"> <li>▲ Integrate OEM Circuitry onto Drive PCB</li> <li>▲ Custom Control Loop Tuned to Motor Characteristics</li> <li>▲ Custom I/O Interface for System Compatibility</li> <li>▲ Preset Switches and Pots to Reduce User Setup</li> <li>▲ Optimized Switching Frequency</li> <li>▲ Ramped Velocity Command for Smooth Acceleration</li> <li>▲ Remove Unused Features to Reduce OEM Cost</li> <li>▲ Application Specific Current and Voltage Limits</li> </ul> |
|---|--|

Feel free to contact Applications Engineering for further information and details.

**Available Accessories**

*ADVANCED* Motion Controls offers a variety of accessories designed to facilitate drive integration into a servo system. Visit [www.a-m-c.com](http://www.a-m-c.com) to see which accessories will assist with your application design and implementation.

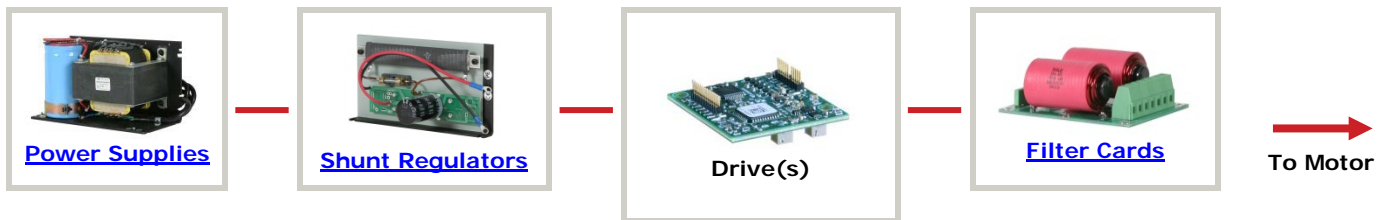

All specifications in this document are subject to change without written notice. Actual product may differ from pictures provided in this document.